



OWNER'S/OPERATOR'S MANUAL

PS30 Dedicated Pole Saw (Pruner)



The **POWER** in Outdoor Power

Completely read and understand this manual **PRIOR** to using this product.

Lea y entienda este manual a fondo, **ANTES** de usar este producto.

Lisez complètement et comprenez ce manuel **AVANT** d'utiliser ce produit.



Limited Warranty Statement

All Maruyama commercial/ industrial products are warranted to the original purchaser to be free from defects in material and workmanship **from the date of purchase** for the time periods listed as follows:

Lifetime for solid steel driveshaft and ignition coils.

5 years for qualified IRON 5-YR™ commercial, institutional, or industrial use.

1 year for residential or **2 years** for commercial use with competitor's oil.

90 days for rental use.

Engine - Refer to engine manufacturer's warranty statement. Only Maruyama engines are covered by this limited warranty statement.

Any part of a Maruyama product found to be defective within the applicable warranty period shall, at Maruyama's option, be repaired or replaced without charge. Warranty consideration is obtained by delivering any Maruyama product believed to be defective to an Authorized Maruyama Servicing Dealer within the applicable warranty period.

The purchaser shall not be charged for diagnostic labor that leads to the determination that a warranted part is defective, if the diagnostic work is performed at a Maruyama Dealer.

Any warranted part which is not scheduled for replacement as required maintenance, or which is scheduled only for regular inspection to the effect of "repair or replace as necessary" shall be warranted for the warranty period. Any warranted part, which is scheduled for replacement as, required maintenance shall be warranted for the period of time up to the first scheduled replacement point for that part. Maruyama Mfg. Co., Inc. is liable for damages to other engine components caused by the failure of a warranted part still under warranty.

The purchaser is responsible for the performance of the required maintenance, as defined by Maruyama Mfg. Co., Inc. in the Owner's/Operator's Manual.

EMISSION-RELATED PARTS WARRANTY: In addition to the above warranty coverage, Maruyama Mfg. Co., Inc. will repair or replace, free of charge, for the original purchaser and each subsequent purchaser any emission-related part or parts found to be defective in material and workmanship for two (2) years from original retail delivery date **except catalytic converter. Catalytic converter is warranted one year from original retail delivery date. Emission-related parts are the carburetor assembly, the ignition coil assembly, the ignition rotor and the spark plug and catalytic converter.** Any replacement part that is equivalent in performance and durability may be used in non-warranty maintenance or repairs, and shall not reduce the warranty obligations of Maruyama Mfg. Co., Inc.

Effective June 1, 2000

This warranty does not cover the following:

1. Maintenance items (excluding defects in materials and workmanship) including hoses, spark plugs, starter rope, air and fuel filters, clutch shoes, vibration isolators, throttle cables and all cutting attachments, etc.
2. Extra expenses including shipping and handling, travel, payment for lost time or pay and for any inconvenience and storage.
3. Alterations or modifications including aftermarket parts not authorized by Maruyama U.S., Inc.
4. Wear, accident, abuse, neglect, misuse, negligence, improper fuels, lubricants, fuel mixtures (when applicable), or failure to operate or maintain the product in accordance with instructions approved by Maruyama.

Repair or replacement as provided under this warranty is the exclusive remedy of the consumer. Maruyama shall not be liable for any incidental or consequential damages for breach of any express or implied warranty on these products except to the extent prohibited by applicable law. Any implied warranty of merchantability or fitness for a particular purpose on these products is limited in duration to the warranty period as defined in the limited warranty statement. Maruyama reserves the rights to change or improve the design of the product without notice and does not assume obligation to update previously manufactured products.

This warranty provides you with specific legal rights, which may vary from state to state.

It is the Owner's and Dealer's responsibility to make sure the Warranty Registration Card is properly filled out and mailed to Maruyama U.S., Inc. Proof of purchase and registration will be required in order to obtain warranty service.

To locate an Authorized Maruyama Servicing Dealer nearest you, contact:

Maruyama U.S., Inc.
4770 Mercantile Drive, suite 100,
Fort Worth, TX 76137
(940) 383-7400
maruyama@maruyama-us.com
www.maruyama-us.com

Effective June 1, 2000

⚠ WARNING: ⚠

The engine exhaust from this product contains chemicals known to the State of California to cause cancer, birth defects or other reproductive harm.

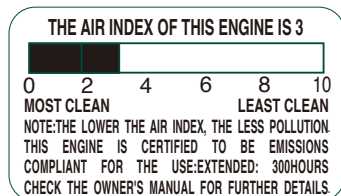

CER230HT

FEDERAL EMISSION CONTROL WARRANTY STATEMENT YOUR WARRANTY RIGHTS AND OBLIGATIONS

The **U.S. Environmental Protection Agency (EPA)** and Maruyama Manufacturing Company, Inc. are pleased to explain the **emission control system warranty** on your small off-road engine. New 1997 and later model year small off-road engines must be designed, built and equipped, at the time of sale, to meet the U.S. EPA regulations for small off-road engines. The equipment engine must be free from defects in materials and workmanship which cause it to fail to conform with U.S. EPA standards for the first two years of engine use from the date of sale to the ultimate purchaser. Maruyama Manufacturing Company, Inc. must warrant the emission control system on your small off-road engine for the period of time listed above provided there has been no abuse, neglect or improper maintenance of your small off-road engine.

Emission durability of 300 hours.

Your emission control system may include parts such as the carburetor or fuel injection system, the ignition system, and catalytic converter. Also included may be hoses, belts, and connectors and other emission related assemblies.

Where a warrantable condition exists, Maruyama Manufacturing Company, Inc. will repair your small off-road engine at no cost to you, including diagnosis (if the diagnostic work is performed at an authorized dealer), parts, and labor.

MANUFACTURER'S WARRANTY COVERAGE:

The 1997 and later model year small off-road engines are warranted for two years. If any emission-related part on your engine is defective, the part will be repaired or replaced by Maruyama Manufacturing Company, Inc. free of charge.

Product Description

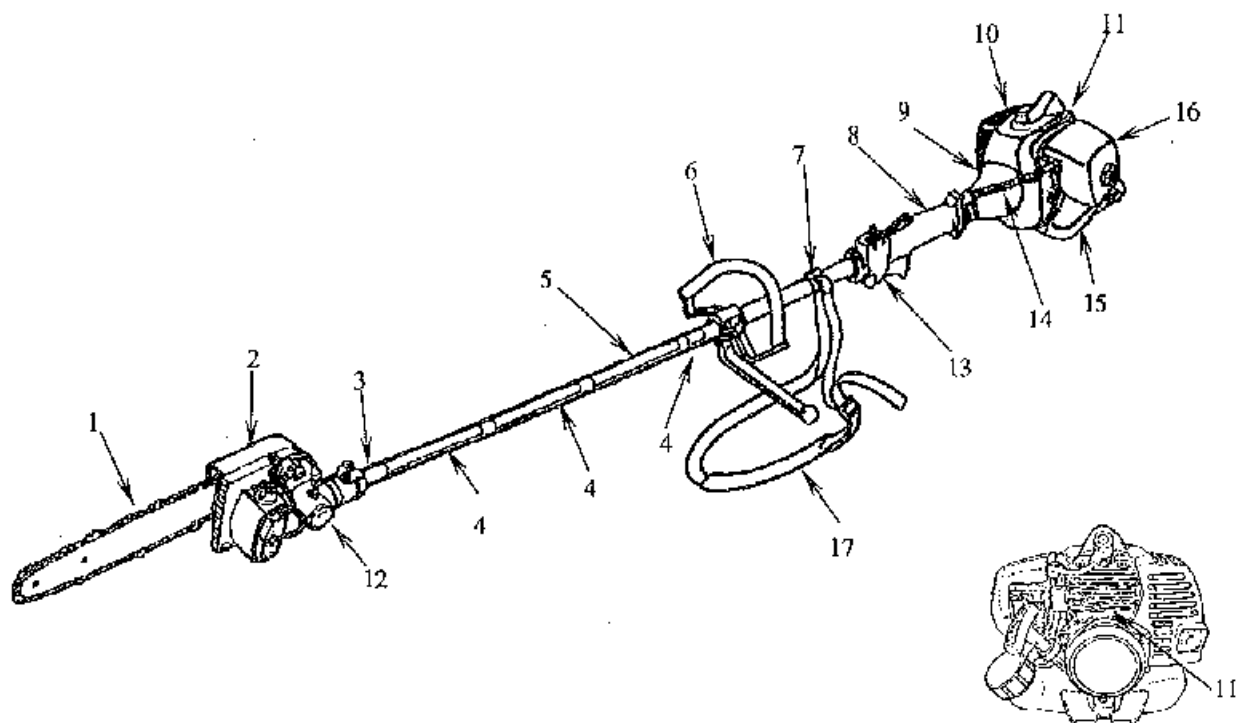

- 1. Chain and Guide Bar
- 2. Pruner Head
- 3. Shaft Assembly
- 4. Safety Decal
- 5. Model Name
- 6. Loop Handle
- 7. Attachment Ring for Shoulder Strap
- 8. Shaft Grip
- 9. Clutch Drum Housing

- 10. Engine
- 11. Serial Number (on rear of engine)
- 12. Gearcase
- 13. Throttle Trigger and Stop Switch
- 14. Throttle Cable and Stop Switch Wires
- 15. Fuel Tank
- 16. Air Filter
- 17. Shoulder Strap

Introduction

Thank you for purchasing a MARUYAMA product.

MARUYAMA, its distributors, and dealers want you to be completely satisfied with your new product. Please feel free to contact your local Authorized Service Dealer for help with service, genuine MARUYAMA parts, or other information you may require.

Whenever you contact your Authorized Service Dealer or the factory, always know the serial number of your product. This number will help the Service Dealer or Service Representative provide exact information about your specific product. You will find the model and serial number located in a unique place on the product (Product Description on page US-7).

For your convenience, write the product model name and serial number in the space below.

Model Name _____
Serial No. _____

Read this manual carefully to learn how to operate and maintain your product correctly. Reading this manual will help you and others avoid personal injury and damage to the product.

Although MARUYAMA designs, produces and markets safe, state-of-the-art products, you are responsible for using the product properly and safely. You are also responsible for training persons who you allow to use the product about safe operation.

The MARUYAMA warning system in this manual identifies potential hazards and has special safety messages that help you and others avoid personal injury, even death.

DANGER, WARNING and CAUTION are signal words used to identify the level of hazard. However, regardless of the hazard, be extremely careful.

DANGER signals an extreme hazard that will cause serious injury or death if the recommended precautions are not followed.

WARNING signals a hazard that may cause serious injury or death if the recommended precautions are not followed.

CAUTION signals a hazard that may cause minor or moderate injury if the recommended precautions are not followed. Two other words are also used to highlight information. “Important” calls attention to special mechanical information and “Note” emphasizes general information worthy of special attention.

Safety

Operator Safety

1. Read and understand this Owner’s/Operator’s Manual before using this product. Be thoroughly familiar with the proper use of this product.
2. Never allow children to operate the Pruner. It is not a toy. Never allow adults to operate the unit without first reading the Owner’s/Operator’s Manual.
3. Always wear eye protection that complies with ANSI (American National Standards Institute) Z87-1.



4. Always wear hearing protection.



5. Always wear heavy, long pants, a long sleeved shirt, boots and gloves. Do not wear loose clothing, jewelry, short pants, sandals, or go barefoot. Secure hair so it is above shoulder length.
6. Never operate this Pruner when you are tired, ill, or under the influence of alcohol, drugs or medication.

7. Never start or run the engine inside a closed room or building. Breathing exhaust fumes can cause death.



8. Keep handles clean of oil, fuel and dirt.

Pruner Safety

1. Make sure the Unit is assembled correctly and that the guide bar and chain are correctly installed and securely fastened as instructed in the Assembly section.
2. Inspect the Unit before each use. Replace damaged parts. Check for fuel leaks. Make sure all fasteners are in place and tightened securely. Follow the maintenance instructions beginning on page US-21.
3. Make sure the chain does not move at engine idle speed. Refer to Idle Speed Adjustment, page US-21.
4. Inspect the chain and guide bar and replace any parts that are cracked, worn or damaged before using the Pruner.
5. Never use a cutting chain or replacement parts that are not approved by MARUYAMA.
6. Maintain the Pruner according to the recommended maintenance intervals and procedures in the Maintenance section.
7. Shut off the engine and be certain the cutting chain has completely stopped moving before inverting the Pruner, performing maintenance on or working on the Pruner machine.
8. If running problems or excessive vibration occur, stop immediately and inspect the unit for the cause. If the cause cannot be determined or is beyond your ability to correct, return the Pruner to your servicing dealer for repair.

Fuel Safety

1. Gasoline is highly flammable and must be handled and stored carefully. Use a container approved for fuel to store gasoline and/or fuel/oil mixture.
2. Mix and pour fuel outdoors, where there are no sparks or flames.
3. Do not smoke near fuel or Pruner, or while using the Pruner.
4. Do not overfill the fuel tank. Stop filling 1/4-1/2 in. (6 mm-13 mm) from the top of the tank.
5. Wipe up any spilled fuel before starting the engine.
6. Move the Pruner at least 10 feet (3m) away from the fueling location before starting the engine.

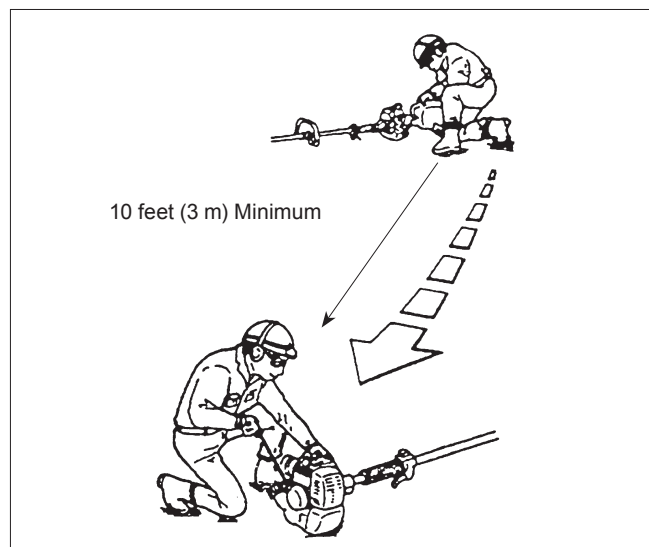

7. Do not remove the fuel tank cap while the engine is running, or right after stopping the engine.
8. Allow the engine to cool before refueling.
9. Drain the tank and run the engine dry before storing the unit.
10. Store fuel and Pruner away from open flame, sparks and excessive heat. Make sure fuel vapors cannot reach sparks or open flames from water heaters, furnaces, electric motors, etc.

Pruner Operating Safety

1. THIS PRUNER CAN CAUSE SERIOUS INJURIES. Read the instructions carefully. Be familiar with all controls and the proper use of the Pruner.
2. The Pruner is designed to cut wood and can therefore be potentially dangerous. Careless or improper use can cause serious or even fatal injury.
3. This Pruner can conduct electricity. Do not use where contact can be made with live electrical circuits. Never use around electrical power sources and lines. Keep the distance between the machine and electrical power line shall be at least 10m (30ft.). Failure to observe this warning can result in serious injury or death.
4. Beware of where material will fall after being cut. Do not stand underneath falling material.
5. Inspect your work area before you begin. Remove objects such as broken glass, nails, wire and rocks which can become dangerous projectiles if thrown by the Pruner. Remove string, rope or similar materials which can become entangled in the Pruner head.
6. This Pruner will throw objects and cut. Keep children, bystanders and animals outside a 50 ft. (15m) radius from the operator and Pruner. Beyond the 50 ft. (15 m) there still may be a risk of injury to bystanders from thrown objects. It is recommended that bystanders wear eye protection. A thrown object can ricochet. (See the Pruner Operating Safety)
7. If you are approached while operating the Pruner, stop the engine and Pruner chain motion.
8. Use the Pruner only in daylight or good artificial light.
9. Do not put hands or feet near or under any rotating parts. Keep clear at all times. Keep all parts of your body away from the Pruner chain and hot surfaces such as the muffler.
10. Keep firm footing and balance. Do not overreach.
11. Use the right tool for the job. Do not use the Pruner for any job that is not recommended by MARUYAMA.

Safety and Instruction Decals



Safety Decals and instructions are easily visible to the operator and are located near any area of potential danger. Replace any decal that is damaged or lost.

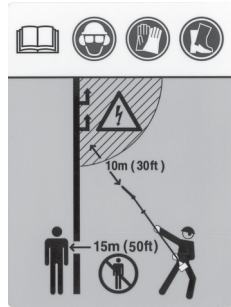

ON SHAFT
(Part No. 231896)



ON SHAFT
(Part No. 219937)

Symbol explanation



Read and understand this Owner's/ Operator's Manual.



- Wear head protection, where there is a risk of falling objects.
- Wear eye protection, while operating the Pruner.
- Wear ear protection, while operating the Pruner.



Wear gloves, while operating the Pruner.



Wear foot protection, while operating the Pruner.

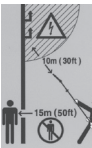

- The distance between the machine and bystanders shall be at least 15m.
- Watch for electrical shock. Keep sufficient distance away from electrical power line.
- The distance between the machine and electrical power line shall be at least 10m (30ft).

Assembly

Assembling Engine and Drive Shaft Assembly

The drive shaft and clutch drum housing are assembled. Attach the clutch drum housing to the engine using the four M5 x 20 screws supplied with the unit.

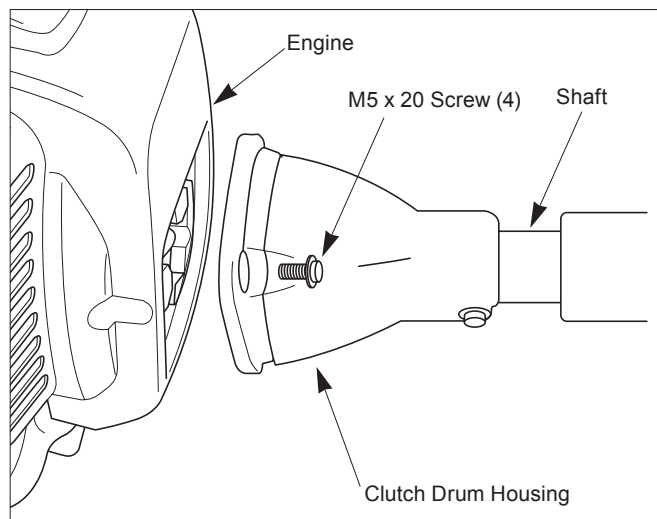

Connecting Throttle Cable and Stop Switch Wires

1. Loosen the knob and remove the air filter cover, insert the throttle cable through the carburetor bracket, then screw a cable adjuster sleeve into the carburetor bracket fully.
2. Position the slotted fitting on the carburetor so the recessed hole for the lug is away from the cable adjuster sleeve.
3. Rotate the carburetor throttle cam and slip the throttle cable through the slot in the slotted fitting, making sure the cable lug drops into the recessed hole.
4. Operate the throttle trigger a few times to make sure that it works correctly.

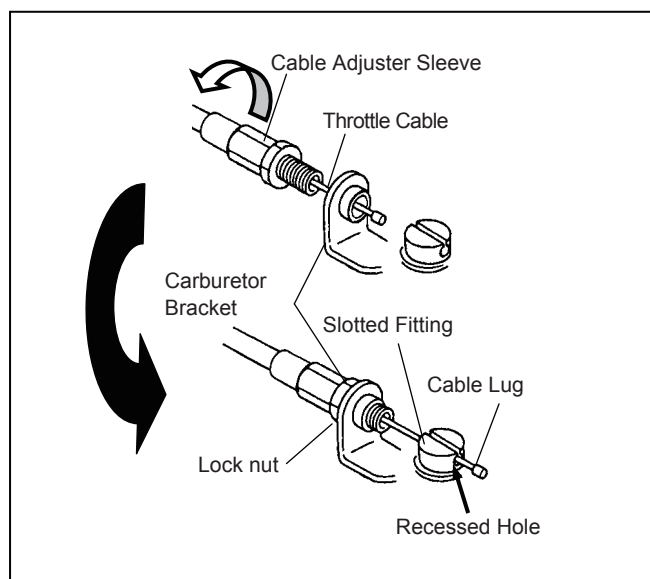

5. Adjust the cable adjuster sleeve so the stop on the carburetor throttle cam just contacts the throttle stop and the cable position keep 1-2mm play between cable lug and slotted fittings when the throttle trigger is fully depressed.

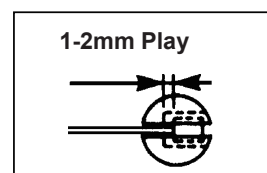

6. When the throttle cable is adjusted correctly, tighten the lock-nut.
7. Plug the stop switch wires into the matching connectors from the engine. Note that wire polarity is not important.
8. Lap and fix the stop switch wires and connectors with clamp.

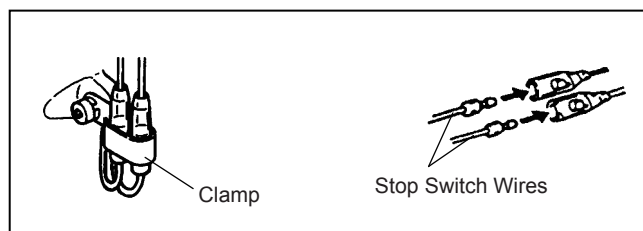

9. Reinstall the air filter cover and tighten the knob.

Guide bar and saw chain installation

⚠ CAUTION

- In order to prevent cuts, be sure to wear gloves when handling the guide bar and saw chain.
- Maintain the tension of the saw chain properly at all times.
- If not enough tension is applied to the saw chain it can easily be dislodged when the saw chain is in motion.
- If too much tension is applied to the guide bar, saw chain and clutch may wear prematurely as a result.

1. Slot the saw chain in the groove of the guide bar, ensuring that the cutter section of the saw chain is facing the front.
2. Engage the saw chain into the sprocket.
3. Insert the groove of the guide bar into the pruner's main unit and adjust the regulating screw to ensure that the adjuster is inserted in the circular hole of the guide bar.
4. Put the chain cover on and temporarily screw it in place using a nut, to the extent that the guide bar can be moved.

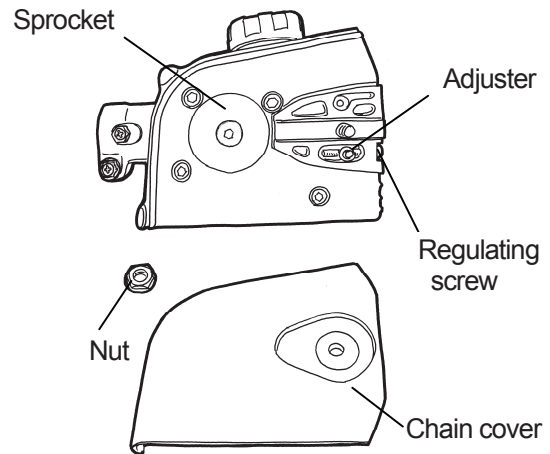
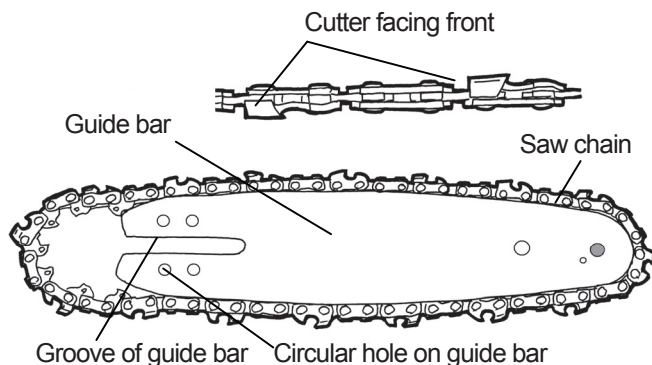

5. Lift up the leading edge of the guide bar and using a screw driver turn the regulating screw clockwise to tighten the saw chain until the saw chain slightly touches the lower side of the guide bar.
6. Securely tighten the nut on the chain cover, using the box spanner, provided as an accessory with the product.
7. Verify that the saw chain on the central section of the guide bar can be lifted by the fingers 3 to 4 mm off the guide bar.

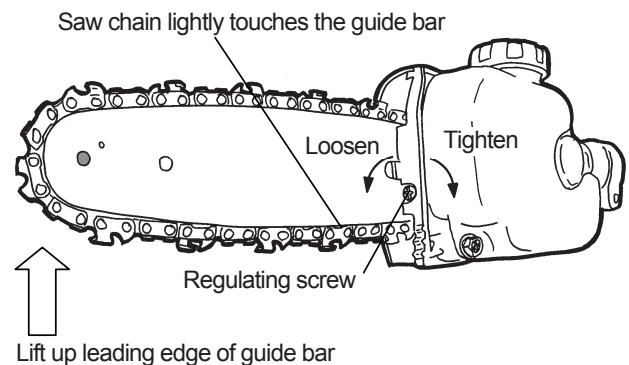

Lifts up 3 to 4 mm when lifted lightly by fingers

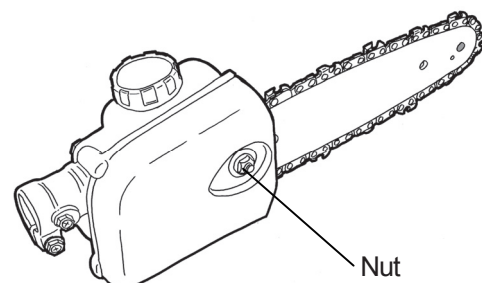

Installing Shaft and Gearcase

Attach the shaft assembly to the Pruner gearcase assembly.

Note: Align the locating hole and install the locating screw through the side of the gearcase. Then tighten the clamping screw.

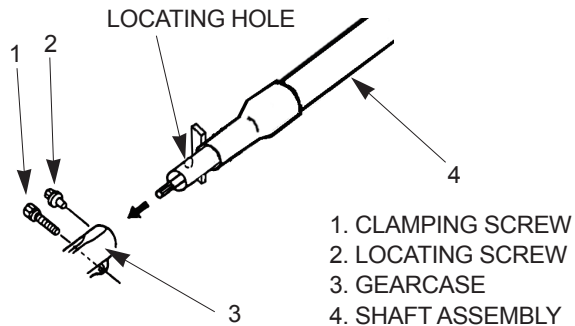

Attaching Strap

Snap the strap hook into the ring on the drive shaft. To detach the strap quickly from the Pruner, pull upward on the red band.

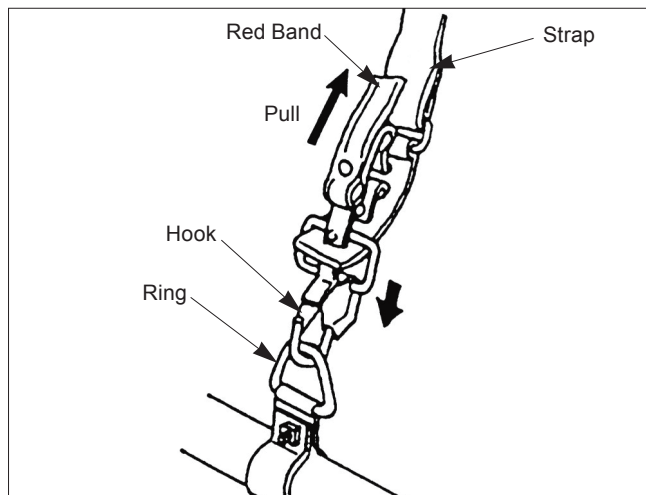

Before operation

Chain oil

- 1) Adding oil
 1. Remove the oil tank cap and pour the chain oil (SAE #10W-30) into the oil tank.
 2. Once the oil has been poured into the oil tank, tighten the oil tank cap to securely close the tank.

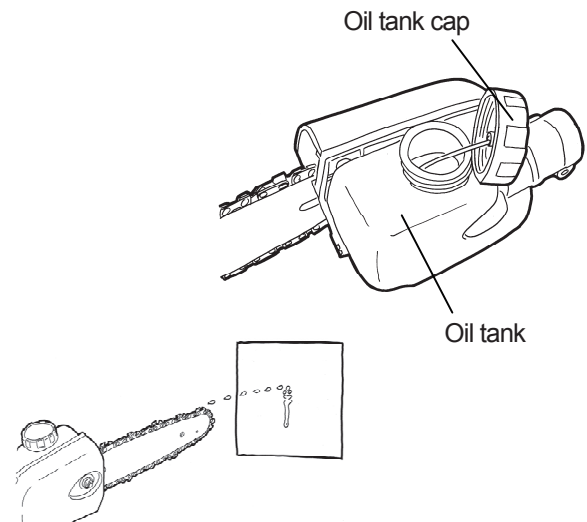

⚠ DANGER

- Ensure that the guide bar and saw chain are installed on the pruner before verifying the discharging rate of the chain oil. The rotator will be exposed and therefore dangerous if the guide bar and the saw chain are not installed on the pruner.

The regulating screw has three positions, Minimum, Intermediate and Maximum, only.

The regulating screw is set to Intermediate at the time of shipping. It is recommended that the product be used with this setting for ordinary use.

- Increase the discharging rate when cutting hard branches or branches with a lot of resin (pitch), or when the viscosity of the oil is high during winter.

1. Insert a minus screw driver into the regulating screw at the bottom of the main unit.

⚠ CAUTION

- It may take some time before the oil begins to discharge once the oil has been added to a new product or when oil has been added to an empty tank. Do not turn the pruner on at a high speed in such circumstances.
- When a new chain is to be used, immerse the chain in chain oil for some time prior to installing it on the pruner, or pour the oil directly on to the chain and the guide bar, after installing it on the pruner. If they are not properly lubricated with oil the pruner may seize.

2. When applying pressure with the minus screw driver, turn the screw to the right (clockwise) to reduce the discharging rate and to the left (counterclockwise) to increase the discharging rate.
3. Turn the engine on and turn the saw chain, with the guide bar facing the ground or tree. Oil will attach to the ground or tree, if the oil is discharging.

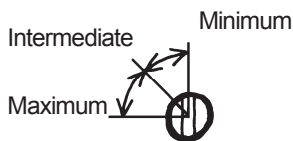
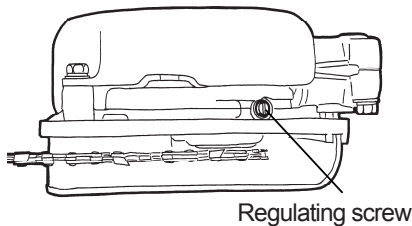

Be sure to turn the screw while applying pressure to it with the screwdriver.

⚠ CAUTION

- Using the pruner with a saw chain too loose may result in the saw chain becoming dislodged and could cause an accident. Please be sure to check the tension of the saw chain before starting any work.

Oil and Fuel

⚠ DANGER

POTENTIAL HAZARD

- In certain conditions gasoline is extremely flammable and highly explosive.

WHAT CAN HAPPEN

- A fire or explosion from gasoline can burn you, others, and cause property damage.

HOW TO AVOID THE HAZARD

- Use a funnel and fill the fuel tank outdoors, in an open area, when the engine is cold. Wipe up any gasoline that spills.
- Do not fill the fuel tank completely full. Add gasoline to the fuel tank until the level is 1/4 to 1/2 in. (6 mm to 13 mm) below the bottom of the filler neck. This empty space in the tank allows gasoline to expand.
- Never smoke when handling gasoline, and stay away from an open flame or where gasoline fumes may be ignited by a spark.
- Store gasoline in an approved container and keep it out of the reach of children.
- Never buy more than a 30-day supply of gasoline.

1. Do not smoke near fuel.
2. Mix and pour fuel outdoors and where there are no sparks or flames.
3. Always shut off the engine before refueling. Never remove the fuel tank cap while the engine is running or just right after stopping the engine.

⚠ WARNING

POTENTIAL HAZARD

- Gasoline contains gasses that can build up pressure inside a gas tank.

WHAT CAN HAPPEN

- Fuel can be sprayed on you when removing gas cap.

HOW TO AVOID THE HAZARD

- Remove fuel cap slowly to avoid injury from fuel spray.

4. Always open the fuel tank cap slowly to release any possible overpressure inside the tank.
5. Do not overfill the fuel tank. Stop filling 1/4-1/2 in. (6 mm-13 mm) from the top of the tank.
6. Tighten the fuel tank cap carefully but firmly after refilling.
7. Wipe up any spilled fuel before starting the engine.
8. Move the Pruner at least 10 feet (3m) away from the fueling location and fuel storage container before starting the engine.

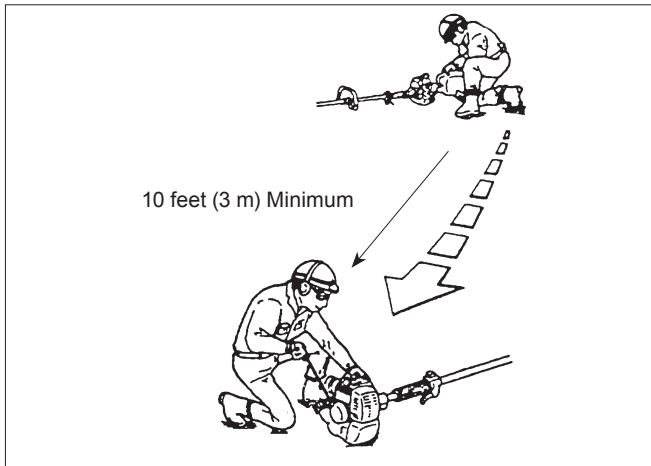

Recommended Oil Type

Only use a two-stroke engine oil formulated for use in high-performance, air-cooled two-stroke engines. MARUYAMA brand two-stroke oil is formulated for use in high-performance, air-cooled two-stroke engines.

IMPORTANT: Do not use National Marine Manufacturer's Association (NMMA) or BIA certified oils. This type of two-stroke engine oil does not have the proper additives for aircooled, two-stroke engines and can cause engine damage.

Do not use automotive motor oil. This type of oil does not have the proper additives for aircooled, two-stroke engines and can cause engine damage.

Recommended Fuel Type

Use clean, fresh lead-free gasoline, including *oxygenated* or *reformulated* gasoline, with an octane rating of 89 or higher. To ensure freshness, purchase only the

quantity of gasoline that can be used in 30 days. Use of lead-free gasoline results in fewer combustion chamber deposits and longer spark plug life. Use of premium grade fuel is not necessary or recommended.

Use of Fuel Additives

IMPORTANT: NEVER USE ALCOHOL, GASOHOL CONTAINING MORE THAN 10% ALCOHOL BECAUSE ENGINE FUEL SYSTEM DAMAGE COULD RESULT.

DO NOT USE FUEL ADDITIVES OTHER THAN THOSE MANUFACTURED FOR FUEL STABILIZATION DURING STORAGE SUCH AS MARUYAMA'S STABILIZER/CONDITIONER OR A SIMILAR PRODUCT. MARUYAMA'S STABILIZER/CONDITIONER IS A PETROLEUM DISTILLATE BASED CONDITIONER/STABILIZER.

MARUYAMA DOES NOT RECOMMEND STABILIZERS WITH AN ALCOHOL BASE SUCH AS ETHANOL, METHANOL OR ISOPROPYL. ADDITIVES SHOULD NOT BE USED TO TRY TO ENHANCE THE POWER OR PERFORMANCE OF MACHINE.

Mixing Gasoline And Oil

IMPORTANT: The engine used on this Pruner is of a two-stroke design. The internal moving parts of the engine, i.e., crankshaft bearings, piston pin bearings and piston to cylinder wall contact surfaces, require oil mixed with the gasoline for lubrication.

Failure to add oil to the gasoline or failure to mix oil with the gasoline at the appropriate ratio will cause major engine damage which will void your warranty.

For your fuel premix, use MARUYAMA Premium two-stroke Oil Mix, or equivalent ISO-L-EGD & JASO FD oil with a minimum 89 octane high quality gasoline. MARUYAMA two-stroke oil is specially formulated to meet the requirements of high-performance, low-emission air-cooled two-stroke engines. Use of other oils may lead to service issues which may not be covered by your warranty.

Fuel Mixture

The fuel: oil ratio is 50 parts gasoline to 1 part oil or 50:1.



Note: Never use a mixing ratio less than 50:1 regardless of the oil package mixing instructions. Ratios less than 50:1, (for example, 60:1, 80:1, 100:1), reduce the amount of lubrication to the internal moving parts of the engine and can cause damage.

Fuel Mixture Chart

Gasoline	50:1 two-stroke oil
1 gallon	2.6 oz.
2 gallons	5.1 oz.
5 gallons	12.8 oz.
1 liter	20 mL
5 liters	100 mL

Mixing Instructions

IMPORTANT: Never mix gasoline and oil directly in the Pruner fuel tank.

1. Always mix fuel and oil in a clean container approved for gasoline.
2. Mark the container to identify it as fuel mix for the Pruner.
3. Use regular unleaded gasoline and fill the container with half the required amount of gasoline.
4. Pour the correct amount of oil into the container then add the remaining amount of gasoline.
5. Close the container tightly and shake it momentarily to evenly mix the oil and the gasoline before filling the fuel tank on the Pruner.

6. When refilling the Pruner fuel tank, clean around the fuel tank cap to prevent dirt and debris from entering the tank during cap removal.
7. Always shake the premix fuel container momentarily before filling the fuel tank.
8. Always use a spout or funnel when fueling to reduce fuel spillage.
9. Fill the tank only to within 1/4-1/2 in. (6 mm-13 mm) from the top of the tank. Avoid filling to the top of the tank filler neck.

Starting And Stopping Before Starting The Engine

1. Fill the fuel tank as instructed in the Before Operation section of this manual (US-14).
2. Rest the Pruner on the ground.
3. Make sure the chain and guide bar are clear of any broken glass, nails, wire, rocks or other debris.
4. Keep all bystanders, children and animals away from the working area.

Cold Starting Procedure

This Pruner is equipped with a fuel primer and a choke system. To start a “cold” engine properly, perform the following procedure:

1. Pump the primer bulb at the bottom of the carburetor until fuel can be seen flowing through the fuel return line to the fuel tank. (Flowing fuel should be almost clear, not foamy or full of bubbles.)

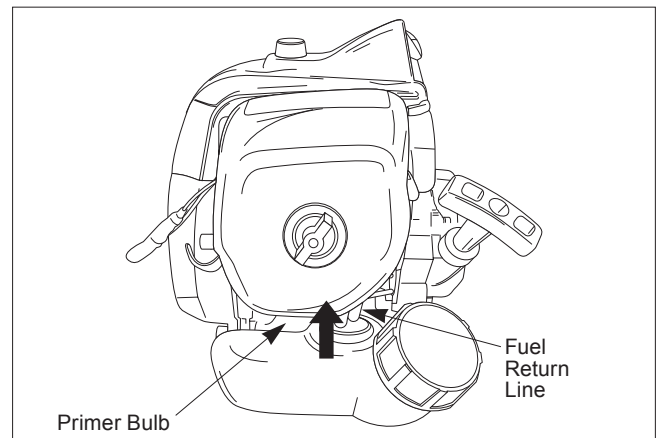

2. Move the choke lever to the closed () position and move the stop switch to the “ON” position.

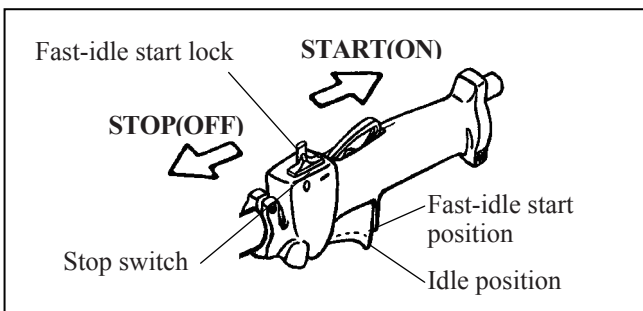
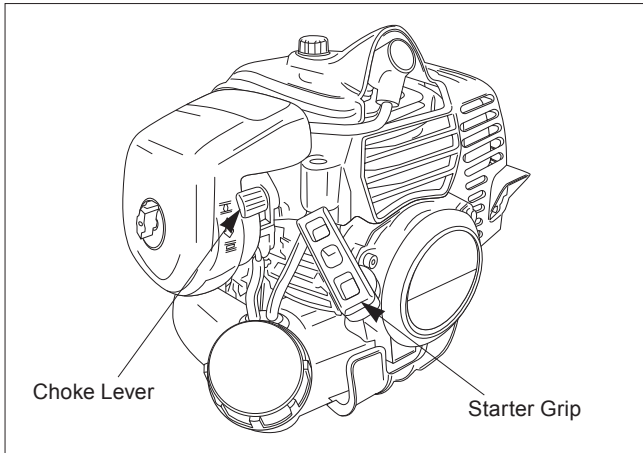

WARNING

POTENTIAL HAZARD

- The components of your recoilstarter assembly are under high spring tension. If improperly disassembled these parts may strike you with considerable force, possibly causing personal injury.

WHAT CAN HAPPEN

- Contact with the parts can cause severe personal injury.

HOW TO AVOID THE HAZARD

- Never attempt to disassemble your recoil starter assembly yourself. Always consult your authorized MARUYAMA dealer for repair by qualified service technicians.

CAUTION

- Do not pull the Starter rope all the way out.

3. Lock the throttle trigger in the fast-idle start position, then pull the starter grip.
4. After the engine starts, squeeze and release the throttle trigger to return it to the idle position, then move the choke lever to the open () position.

If the engine stops running before you move the choke lever to the open () position:

- A. Go ahead and open the choke.
- B. Make sure the throttle trigger is set to the fast-idle position.
- C. Pull the starter grip until the engine starts.

Hot Restart

To start an engine that is already warmed up (hot restart), or if the ambient temperature exceeds 68°F (20°C):

1. Pump the primer bulb at the bottom of the carburetor until fuel can be seen flowing through the fuel return line to the fuel tank.
2. Move the choke lever to the open () position and move the stop switch to the “ON” position.
3. Leave the throttle trigger in the idle position and pull the starter grip.
4. If the engine fails to start after three to four pulls, follow the instruction in the Cold Starting Procedure section (US-17).

If the engine fails to start after you follow the above procedures, contact an authorized MARUYAMA dealer.

To Stop The Engine

1. Release the throttle trigger.
2. Slide the stop switch to the “STOP” position.

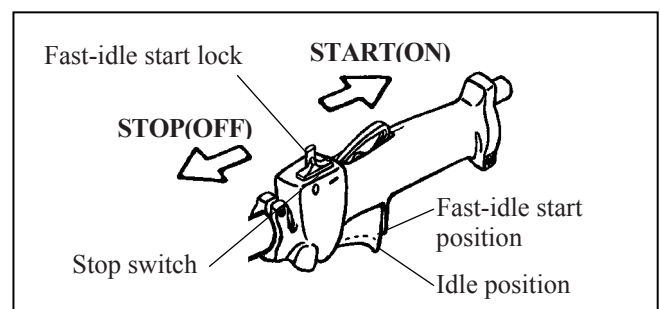

Operation

⚠ DANGER

- Do not stand immediately below the branch that is to be cut. The branch may fall directly below and the branch may also bounce off other branches or the ground in an unexpected direction and cause injury to the worker.
- Do not allow anyone to enter within a 15 meter radius.
- The Pruner is not insulated to prevent electric shock. Keep it away from any power lines with at least 15 meters when working, as there is threat of electrocution.

Working position

1. Choose a working position where the inclination of the pole remains at 60 degrees or less.
2. Start cutting from the lower branches first so that the branches will fall off easily when cut.
3. The cut branches may fall towards the worker, so be sure to select a location that enables a stable footing and provides an easy escape in the case of an emergency.

⚠ WARNING

- Wear a hat or helmet, protective glasses, gloves and ear plugs while working. Furthermore, wear a dust mask whenever a lot of pollen or chipping powder is expected, which may be harmful for the health.

Cutting wood

1. Turn the pruner on full throttle and press the saw chain lightly against the wood to cut.
2. The cutting capacity is reduced when the engine revolution is slowed down and the saw chain is pressed hard against the wood.

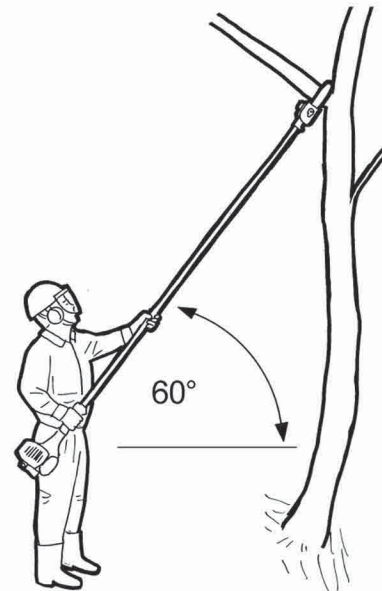

IMPORTANT:

- Pressing the saw chain hard against the wood not only tires the operator quicker but also quickens the wear of the saw chain and guide bar.
- If wood cannot be cut without pressing the saw chain hard against it, this indicates that the saw chain is becoming dull. In such cases, either sharpen the saw chain or replace it with a new chain.

Operation

Pruning thick branches

Attempting to cut a thick branch in one go often results in the guide bar jamming in the branch or otherwise encountering difficulties in cutting. The method described below makes cutting thick branches easier:

1. First of all, cut a section slightly away and on the lower side of the desired area of the branch to be cut.
2. Then, start cutting from the upper side of the branch.
3. hereafter, cut into the lower side where the desired area of branch is to be cut.
4. Finally, cut through from the upper side where the branch is to be cut, cutting the branch off.

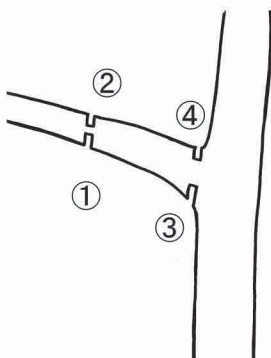

IMPORTANT: If the guide bar or saw chain jams into the branch, do not force it. Widen the cut using a wedge to remove the pruner and try cutting it again. Forcing the pruner may damage the main unit of the pruner and cause a malfunction of the pruner.

Saw chain tension adjustments

⚠ WARNING

- When using the pruner be sure to turn the engine off before making any inspections or any adjustments.
- Do not make any adjustments when the guide bar or saw chain is still hot immediately after using the pruner. Wait until it has cooled before making any adjustments.

1. Turn the nut on the chain cover once to loosen it.
2. Lift up the leading edge of the guide bar and turn the regulating screw to tighten the saw chain. Turning the screw clockwise tightens the saw chain, whereas turning it counterclockwise loosens the saw chain.
3. Securely tighten the nut on the chain cover.
4. Verify that the saw chain on the central section of the guide bar can be lifted with fingers 3 to 4 mm off the guide bar.

IMPORTANT: To detach the strap quickly from the Pruner, pull upward on the red band.

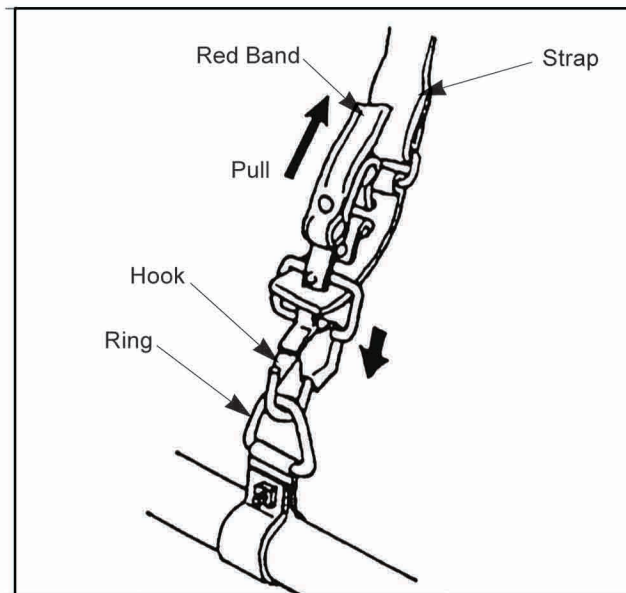

Maintenance

Maintenance, replacement or repair of emission control devices and systems may be performed by any repair establishment or individual; however, warranty repairs must be performed by a dealer or service center authorized by MARUYAMA Manufacturing Company, Inc. The use of parts that are not equivalent in performance and durability to authorized parts may impair the effectiveness of the emission control system and may have a bearing on the outcome of a warranty claim.

Maintenance on today's low-emission engines is even more critical for longest life and best performance. particularly critical are air and fuel filters, spark plug heat range, cooling air intake area and proper gaps of coil and plug.

Idle Speed Adjustment

This Pruner is equipped with non-adjustable fuel mixture carburetor. The engine idle speed is the only adjustment for the operator.

⚠ WARNING

- Idle speed adjustment should be checked each time the unit is operated.

⚠ WARNING

POTENTIAL HAZARD

- Engine must be running to make carburetor adjustments.
- When engine is running, saw chain is moving and other parts are moving.

WHAT CAN HAPPEN

- Contact with moving saw chain or other moving parts could cause serious personal injury or death.

HOW TO AVOID THE HAZARD

- Keep hands, feet and clothing away from saw chain and other moving parts.
- Keep all bystanders and pets away from unit while making carburetor adjustments.

The cutting head may be rotating during idle speed adjustment. Wear the recommended personal protective equipment and observe all safety instructions. Keep hands and body away from the cutting head.

When the throttle trigger is released, the engine should return to an idle speed between 2700 and 3300 RPM, or just below the clutch engagement speed. The cutting head must not rotate and the engine should not stall (stop running) at engine idle speed.

To adjust the engine idle speed, rotate the idle speed adjustment screw on the carburetor.

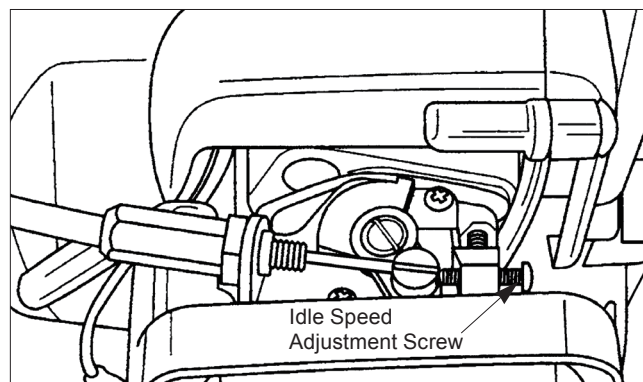

- Turn the idle speed screw in (clockwise) to increase the engine idle speed.
- Turn the screw out (counterclockwise) to decrease the engine idle speed.

If idle speed adjustment is necessary, and after adjustment the cutting head rotates or the engine stalls, stop using the Pruner immediately!

Contact your local authorized MARUYAMA Dealer for assistance and servicing.

Air Filter

Maintenance Interval

- The air filter should be cleaned **daily**, or more often when working in extremely dusty conditions.
- Replace after every 100 hours of operation.

Air Filter Cleaning

1. Loosen the knob and remove the air filter cover.
2. Remove the foam element and filter screen from the air filter body.
3. Clean the foam element and filter screen with warm, soapy water. Let the screen and element dry completely.
4. Apply a light coat of SAE 30 motor oil to the foam element and squeeze out all excess oil.
5. Reassemble the filter screen and foam element to the air filter body.

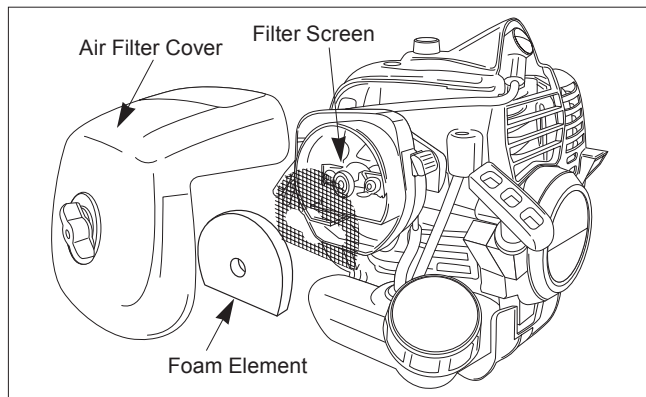

6. Reinstall the air filter cover and tighten the knob.

Fuel Filter

Maintenance Interval

The fuel filter should be replaced after every 100 hours of operation.

Fuel filters needing more frequent replacement may indicate debris in fuel tank.

Fuel Filter Replacement

The fuel filter is attached to the end of the fuel pick-up hose inside the fuel tank.

To replace the fuel filter:

1. Make sure the fuel tank is empty.

2. Remove the fuel cap.
3. Using a wire hook, gently pull the fuel filter out through the fuel filler opening. Use caution not to “fishhook” the fuel tube. Replace immediately if punctured!

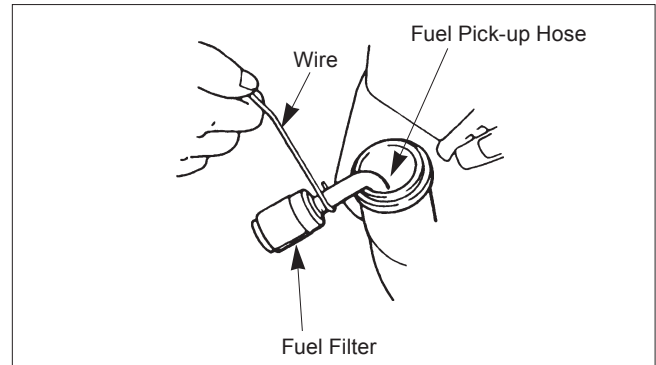

4. Grasp the fuel hose next to the fuel filter fitting and remove the filter, but do not release the hose.
5. While still holding on to the fuel hose, attach the new fuel filter.
6. Drop the new fuel filter back into the fuel tank.
7. Make sure that the fuel filter is not stuck in a corner of the tank, and that the fuel hose is not doubled over (kinked) before refueling.

Spark Plug

Maintenance Interval

- The spark plug should be removed from the engine and checked after each 25 hours of operation.
- Replace the spark plug after every 100 hours of operation.

Spark Plug Maintenance

1. Twist the high tension lead boot on the spark plug back and forth a couple of times to loosen the boot, then pull the boot off of the spark plug.
2. Remove the spark plug.

- Clean the electrodes with a stiff brush.

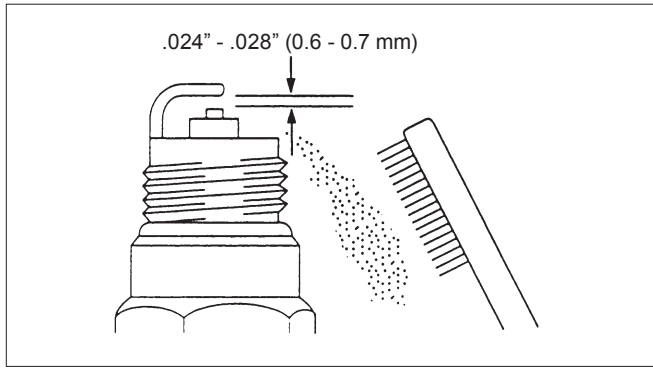

- Adjust the electrode air gap to .024-.028 in. (0.6-0.7 mm).
- Replace the spark plug if it is oil-fouled, damaged, or if the electrodes are worn down.
- Do not overtighten the spark plug when installing. The tightening torque is 95-148 in.-lbs. (10.7-16.6 N·m).
- Always use only the specific heat range of spark plug. This is particularly critical with today's low-emission engines. For best results, use the exact replacement.

Cylinder Cooling Fins

Maintenance Interval

- The cylinder cooling fins should be cleaned after every 25 hours of operation, or once a week, whichever comes first.
- Air must flow freely around and through the cylinder cooling fins to prevent engine overheating. Leaves, grass, dirt and debris buildup on the fins will increase the operating temperature of the engine, which can reduce engine performance and shorten engine life.

Cooling Fin Cleaning

- With the engine at ambient (room) temperature, loosen the knob and remove the air filter cover.

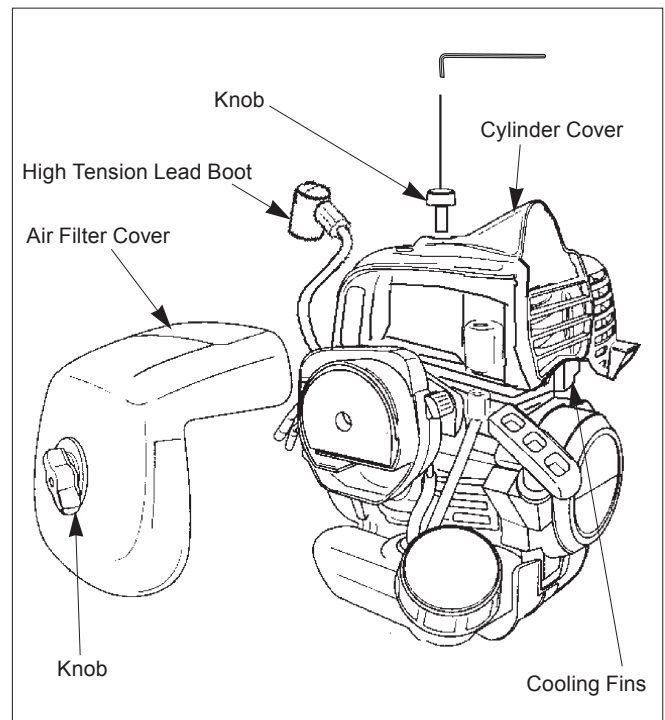

- Twist the high tension lead boot on the spark plug back and forth a couple of times to loosen the boot, then pull the boot off of the spark plug.
- Loosen the knob and lift off the cylinder cover.
- Clean all dirt and debris from the cooling fins and from around the cylinder base.

- DO NOT overlook cleaning of the cooling air intake area below the crankcase and above the fuel tank! This area must be free of debris and obstruction for the engine to cool properly.
- Reinstall the fan cover and the filter cover.

Spark Arrester

⚠ WARNING

POTENTIAL HAZARD

- Muffler surface becomes hot when Pruner is in operation and remains hot for some time after the engine is shut off.

WHAT CAN HAPPEN

- Contact with hot muffler surfaces could cause a burn.

HOW TO AVOID THE HAZARD

- Make sure the muffler is cool before inspecting and cleaning the spark arrester.

Maintenance Interval

- The spark arrester should be inspected and cleaned after every 25 hours of use.
- Replace the screen if it cannot be thoroughly cleaned, or if it is damaged.

Spark Arrester Maintenance

- With the engine at ambient (room) temperature, loosen the knob and remove the air filter cover.
- Twist the high tension lead boot on the spark plug back and forth a couple of times to loosen the boot, then pull the boot off of the spark plug.
- Loosen the knob and lift off the cylinder cover.
- Remove and clean the tail, gasket and spark arrester with a safety solvent and a stiff brush. If any part cannot be thoroughly cleaned, it must be replaced.

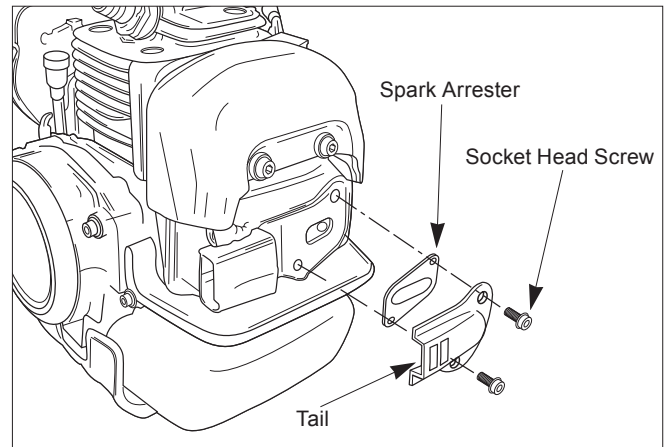

- Reinstall the spark arrester and tail onto the muffler, then reinstall and tighten the two socket head screws.
- Reinstall the cylinder cover and the air filter cover.

Exhaust Muffler

Maintenance Interval

The muffler should be inspected and cleaned after each 100 hours of use.

Muffler Maintenance

- With the engine at ambient (room) temperature, loosen the knob and remove the air cleaner cover.
- Twist the high tension lead boot on the spark plug back and forth a couple of times to loosen the boot, then pull the boot off of the spark plug.
- Loosen the knob and lift off the cylinder cover.
- Remove the spark arrester (see spark arrester maintenance), Clean the muffler with a stiff brush.

IMPORTANT: Don't use solvent for cleaning inside of muffler, because of the catalytic converter in muffler.

Be careful not to allow any dirt or debris to fall into the exhaust port, as this can cause engine damage.

5. Reinstall the spark arrester and tail onto muffler, then reinstall and tighten the two socket head screws.
6. Reinstall the cylinder cover and the air filter cover.

Sharpening saw chain

Whenever wood chips become small and fine or the wood cannot be cut without pressing the pruner hard against it, then it may be necessary to sharpen the saw chain.

1. Tighten the saw chain slightly firmer than usual then secure the pruner's main unit.
2. Place a file with a 4.0 mm (5/32 in.) diameter against the cutter and extend 1/5 of it beyond the cutter.
3. Press the file against the cutter at its base in a 30-degree angle from the vertical line and move the file straight ahead from the inner side to the outer side of the cutter.
4. Shift the file so that it remains in a 90-degree angle against the guide bar.
5. Once one side of the cutter is sharpened, sharpen the other side of the cutter. Be sure to keep the length and angle uniform throughout.

IMPORTANT:

- The spark arrester should be inspected and cleaned after every 25 hours of use.
- Replace the screen if it cannot be thoroughly cleaned, or if it is damaged.

Adjusting depth gauge

The depth gauge determines how deep the cutter cuts into the wood.

1. When the cutter lengths become shorter due to sharpening, the depth gauge must also be cut back.

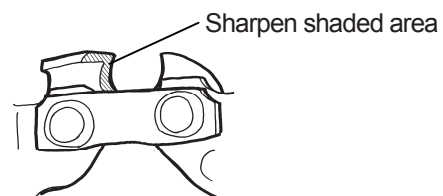
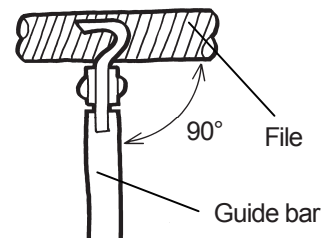
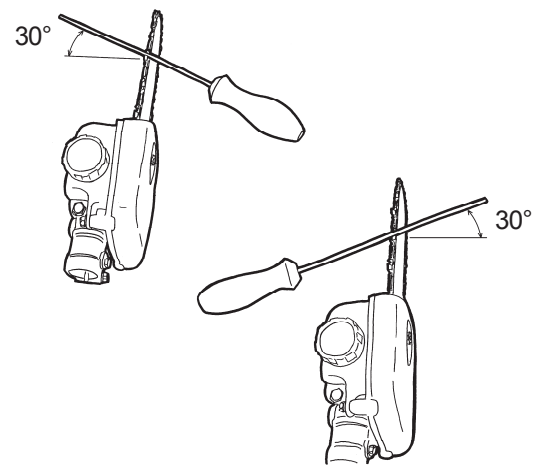

Maintain uniform lengths of cutters

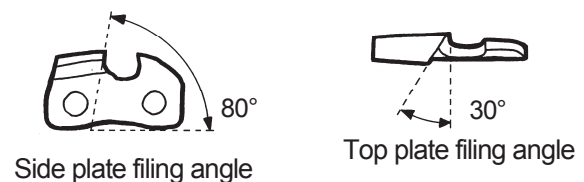
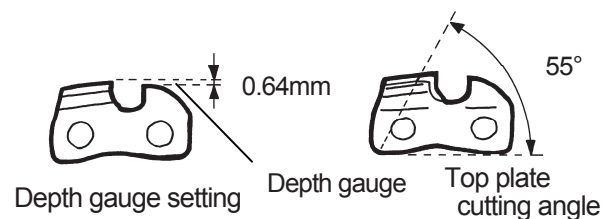
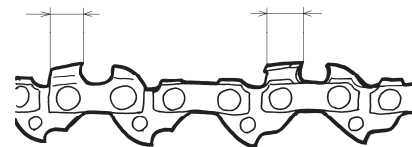

Cutter Maintenance Specifications

2. Cut down the depth gauge using a flat file in a way that the depth gauge is positioned 0.64 mm (0.025 in.) lower than the leading edge of the cutter.
3. Once cut back, grind the tip of the depth gauge round.

IMPORTANT:

Be sure that the depth gauge is not cut back too far, as doing so will result in a faster deterioration of the cutter.

Guide bar care

1. When work using the pruner is finished for the day, remove the guide bar and saw chain from the pruner.
2. Remove any wood chips or other particles attached to the groove of the guide bar or in the oil hole. Be particularly certain that no particles are clogging the oil hole.
3. Remove wood chips and other particles around the oil discharge hole and around the sprocket on the main unit of the pruner.

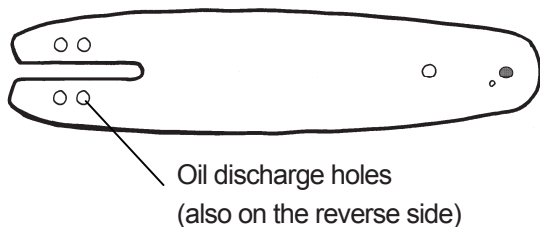

IMPORTANT:

- When installing the guide bar, occasionally switch it to the top and bottom to prevent uneven wear and to extend the life of the guide bar.
- If the oil discharge hole becomes clogged by wood chips or other particles the pruner could seize up.

Inspection of sprocket

1. Inspect the sprocket to ensure that the screw is not loose or that it is not worn out.

2. If the sprocket is worn by 0.3 mm or more, as shown in the diagram below, replace the sprocket. Continuing to use the pruner with the sprocket in such a condition will shorten the life of the saw chain.

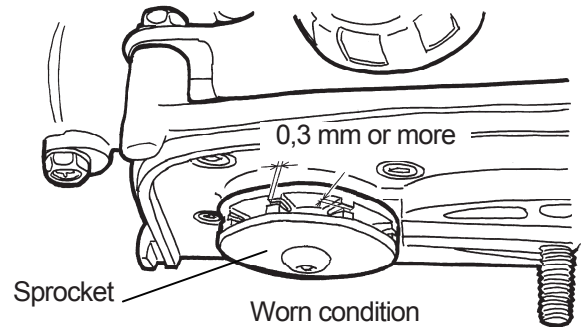

Gear case

1. Remove the gear case from the shaft assembly.
2. Remove the grease plug and prepare some lithium-type grease.
3. Inject enough grease (about 10g) so that some of it spills out through the spline hole, to which the drive shaft is inserted.

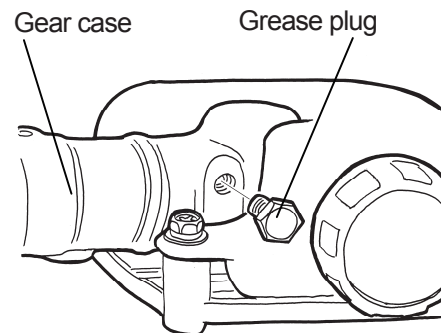

General Cleaning and Tightening

⚠ WARNING

POTENTIAL HAZARD

- When engine is running, saw chain is moving and other parts are moving.

WHAT CAN HAPPEN

- Contact with moving saw chain or other moving parts could cause serious personal injury or death.

HOW TO AVOID THE HAZARD

- Always turn off your pruner before you clean or perform any maintenance on it.

The MARUYAMA Pruner will provide maximum performance for many, many hours if it is maintained properly.

Good maintenance includes regular checking of all fasteners for correct tightness and cleaning the entire machine.

Storage

For long term storage of the Pruner:

1. Empty the fuel tank into a suitable fuel storage container.
2. Pump the primer bulb on the carburetor until all fuel is discharged through the clear fuel return hose.
3. Run the engine to remove any fuel that may remain in the carburetor.
4. Perform all regular maintenance procedures and any needed repairs.
5. Remove the spark plug and squirt a very small amount of oil into the cylinder.

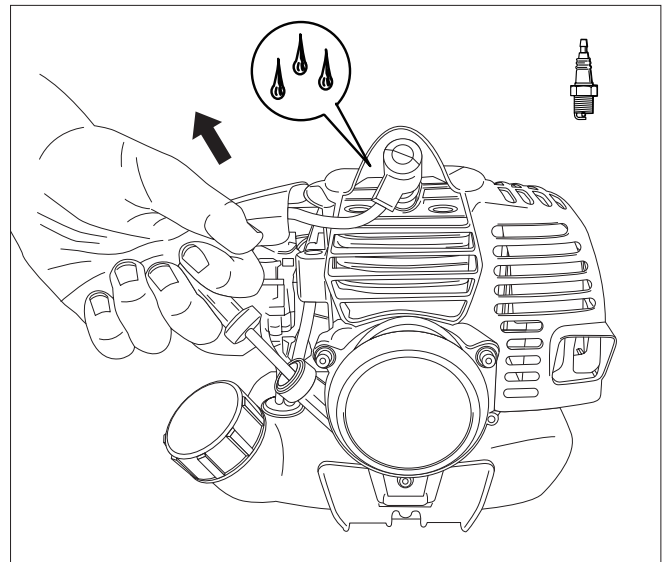

⚠ CAUTION

POTENTIAL HAZARD

- Oil may squirt out of the spark plug opening when you pull the starter grip.

WHAT CAN HAPPEN

- Oil can cause eye injuries.

HOW TO AVOID THE HAZARD

- Protect your eyes and keep your face away from the spark plug opening.

6. Pull the starter grip once.
7. Slowly pull the starter grip to bring the piston to the top of the cylinder (TDC).
8. Reinstall the spark plug.
9. Store the Pruner in a dry place away from excessive heat, sparks or open flame.

Troubleshooting

Problem	Cause	Action
Engine Will Not Start	STOP switch set to off position Empty fuel tank Primer bulb wasn't pushed enough Engine flooded	Move switch to on position Fill fuel tank Press primer bulb until fuel flows through fuel return line Use warm engine starting procedure
Engine Will Not Idle	Idle speed set incorrectly	Set idle speed
Engine Lacks Power or Stall When Cutting	Throttle wire has come loose Dirty air filter Clogged spark arrester or exhaust port.	Tighten throttle wire Clean or replace air filter Clean spark arrester or exhaust port.

If further assistance is required, contact your local authorized MARUYAMA service dealer.

Maintenance Period

Maintenance	Daily	Every 25 hours	Every 50 hours	Every 100 hours
Check and replenish fuel	●			
Check for fuel leakage	●			
Check bolts, nuts and screws for tightness or missing	●			
Check engine idle speed adjustment	●			
■ Clean air filter element	●			
Clean spark plug and adjust electrode gap		●		
■ Remove dust and dirt from cylinder fins		●		
● Clean spark arrester		●		
Tighten bolts and nuts			●	
● Remove carbon deposits in exhaust port			●	
Replace fuel filter				●
● Remove carbon deposits on piston head and combustion chamber				●
● Remove carbon deposits in transfer port				●
Replace fuel tube, fuel tank cap gasket	It is recommended to replace every 3 years			

●: Service to be performed by an authorized MARUYAMA engine dealer.

■: Service more frequently under dusty conditions.

NOTE:

The service intervals indicated are to be used as a guide.

Service to be performed more frequently as necessary depending on operating condition.

Use MARUYAMA standard 50:1 two-stroke engine oil.

Specifications

	PS30
Weight ※ 1(lbs.)	15.0 lbs / 6.8 kg
Engine Displacement (cm ³)	30.1
Anti Vibration	Engine mount
Carburetor	Walbro Diaphragm Type
Ignition System	Solid State
Fuel Tank Capacity (qts.)	0.63 (0.6L)
Gas to Oil Ratio	50:1
Spark Plug	NGK BPM8Y
Spark plug Gap (in.)	.024-.028 (0.6-0.7mm)
EPA and CARB Approved	Phase 3, Tier 3

Emission durability of 300 hours.

※1. Dry weight without fuel, Chain, Bar and Strap.



Maruyama U.S., Inc.

4770 Mercantile Drive, suite100,
Fort Worth, TX 76137 U.S.A.

Phone 940-383-7400

Fax 940-383-7466

www.maruyama.com