

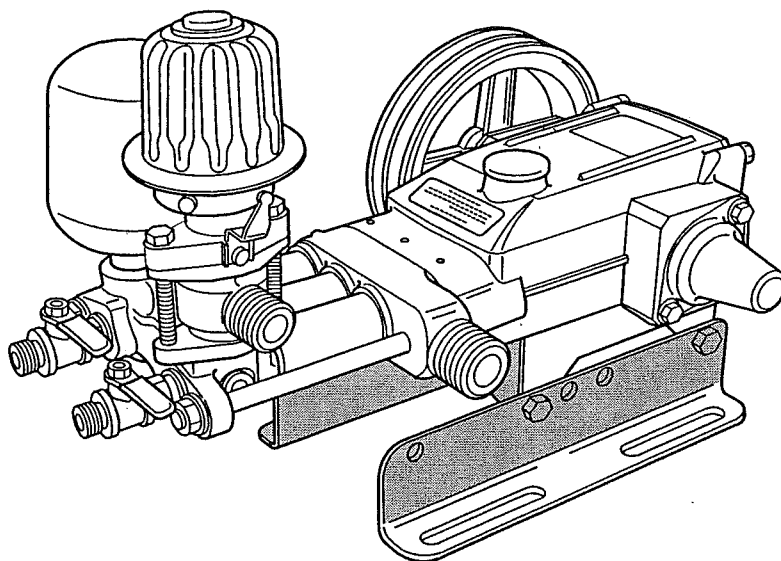

POWER SPRAYER MS154/MS330
PULVÉRISATEUR AUTOMOTEUR
MS154/MS330
POWER SPRAY MS154/MS330



INSTRUCTION MANUAL
MODE D'EMPLOI
MANUAL DE INSTRUCCIONES

Main parts nomenclature

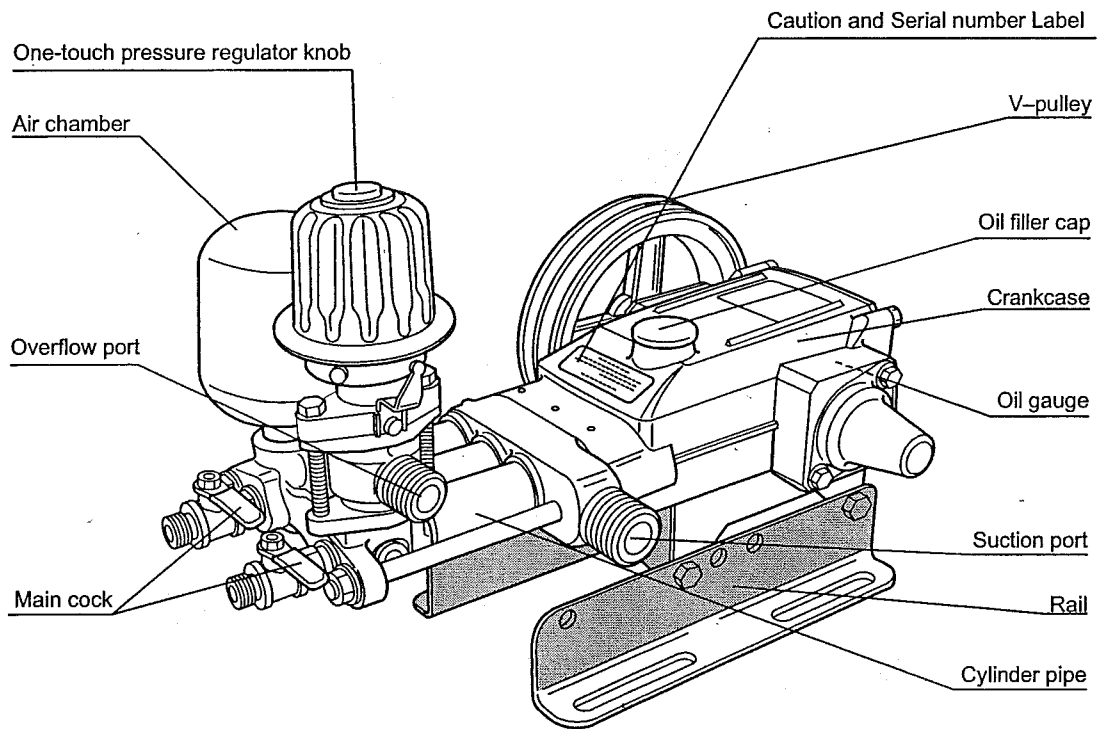

Specifications

Model		MS154		MS330		
Overall height	Overall length (mm)	374		399		
	Overall width (mm)	215		243		
	Overall height (mm)	286		279		
Weight (kgf)		7.2		7.2		
		Maximum	Irrigation	Maximum	Irrigation	
Specifications	Crankshaft speed (rpm)	1000	1400	1050	1300	
	Suction capacity (N/min)	13	17.5	30	35	
	Pressure	MPa	3.5	1.0	3.5	2.5
		(kgf/cm ²)	(35)	(10)	(35)	(25)
Required power	kw	1.0	0.5	2.0	1.9	
	(PS)	(1.4)	(0.7)	(2.8)	(2.6)	
Suction hose		ø13, G ¹ / ₂ (PF ¹ / ₂)		ø19, G ³ / ₄ (PF ³ / ₄)		
Overflow hose		ø13, G ¹ / ₂ (PF ¹ / ₂)				
Main cock		2-G ¹ / ₄ , (2-PF ¹ / ₄)				
Lubricating oil		SAE10W-30, SC or better				
Lubricating oil capacity (N)		0.23		0.42		

Performance curve

MS154

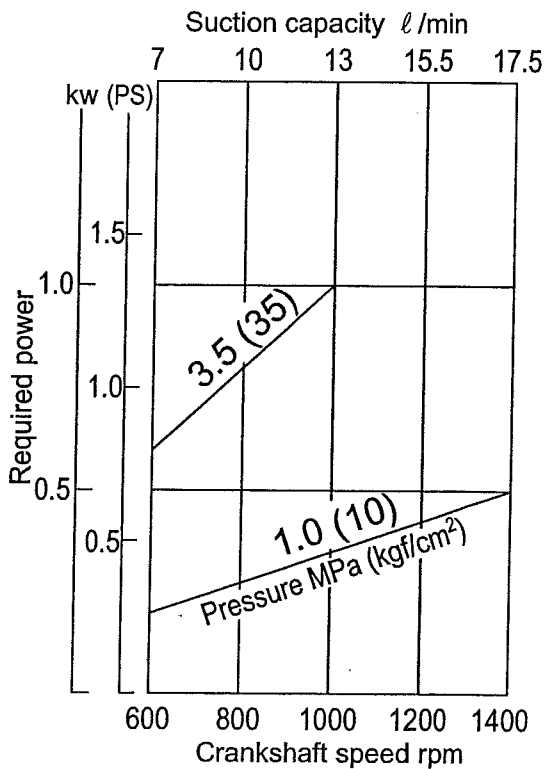

MS330

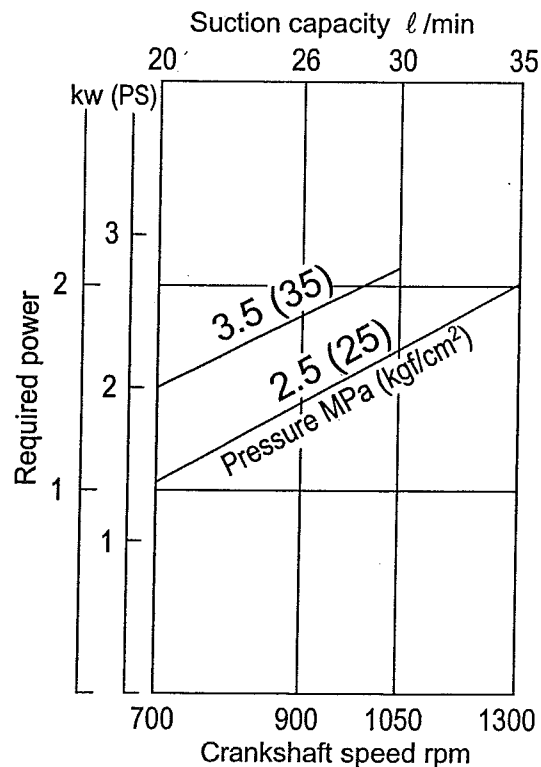

Specifications

Model		MS154		MS330		
Overall height	Overall length	14.72"		15.71"		
	Overall width	8.46"		9.57"		
	Overall height	11.26"		10.89"		
Weight (lbs)		15.9		15.9		
		Maximum	Irrigation	Maximum	Irrigation	
Specifications	Crankshaft speed	(RPM)	1000	1400	1050	1300
	Suction capacity	(GPM)	3.4	4.6	7.9	9.2
	Pressure	PSI	510	146	510	364
Required power	HP	1.3	0.7	2.7	2.5	
Suction hose		dia. 1/2"		dia. 3/4"		
Overflow hose		dia. 1/2"				
Main cock		2-G 1/4" (2-PF 1/4")				
Lubricating oil		SAE10W-30, SC or better				
Lubricating oil capacity (OZ)		8		14.5		

Performance curve

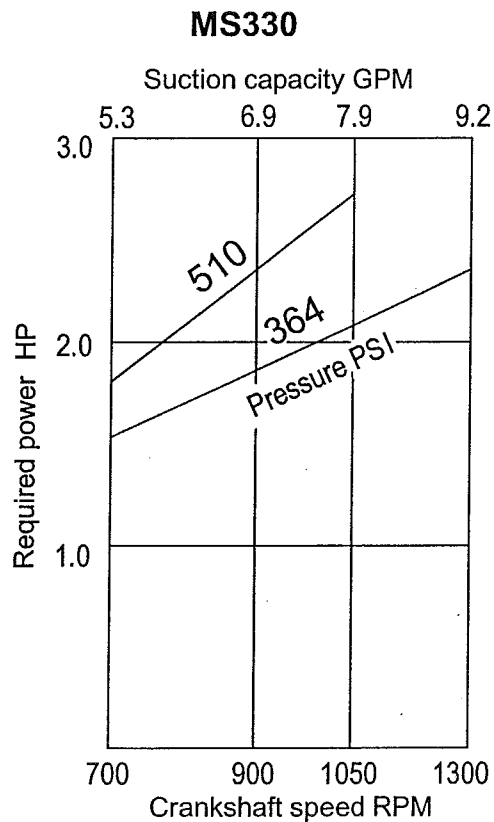
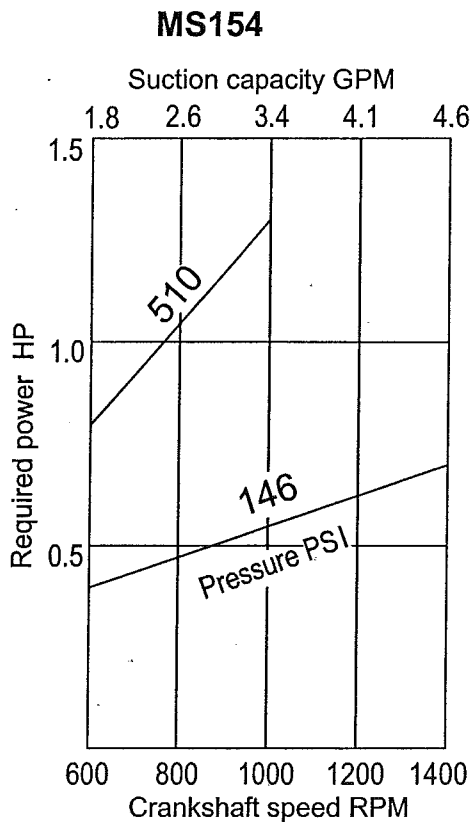

Operating procedure

Preparatory inspection
• Spraying

Be sure to check all the screws for tightness.

1 Lubricating oil.

Fill the lubricating oil into the crankcase up to the center level of the gauge.

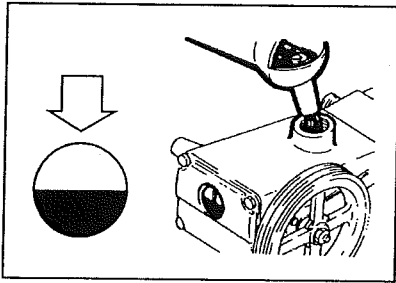

2 Oiling

Feed a few drops of oil into the 3 holes of the crankcase.

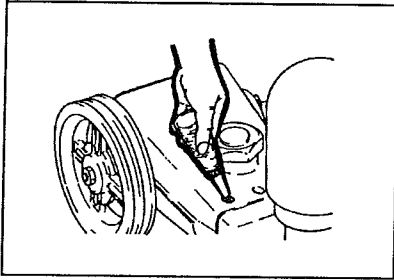

3 Installing the suction hose and overflow hose.

When installing the suction hose, check the condition and presence of sealing gaskets at the threaded couplings.

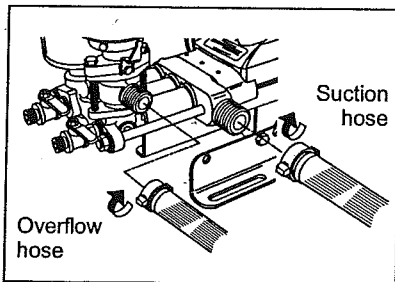

4 Attaching the strainer for the hose coupling.

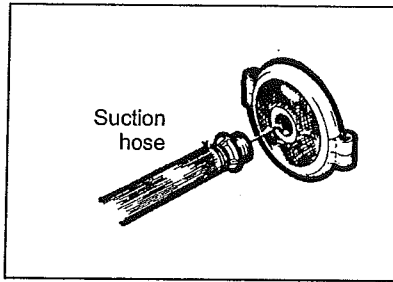

5 Insert the suction hose and overflow hose into the chemical tank.

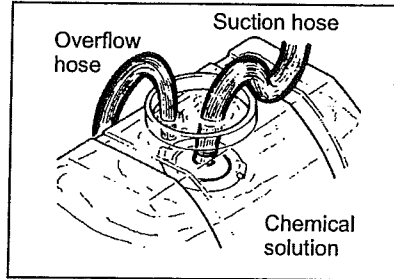

6 Coincide knob of pressure regulator with 0.

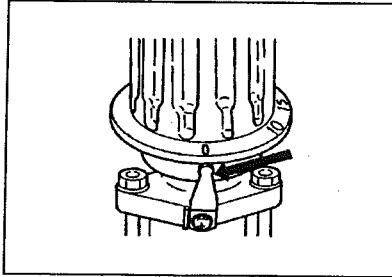

7 Close the valve.

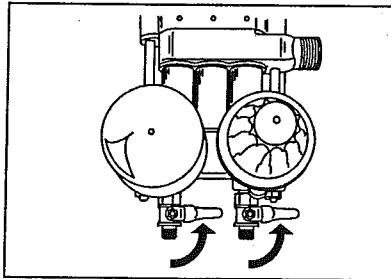

8 Starting

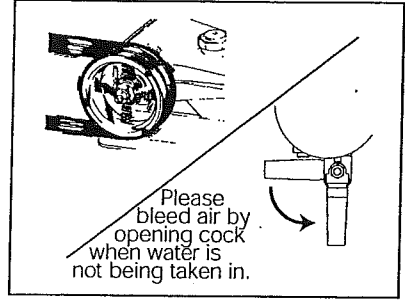

9 Pressure regulation.

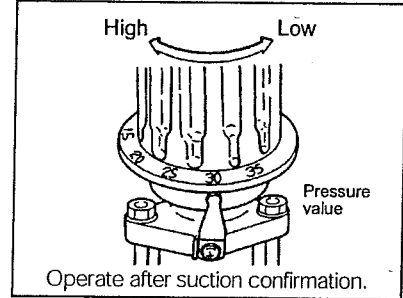

10 Spraying

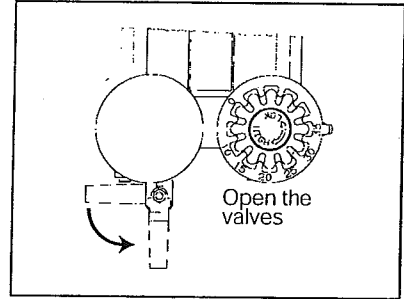

Stopping operation and maintenance

11 Stopping spraying

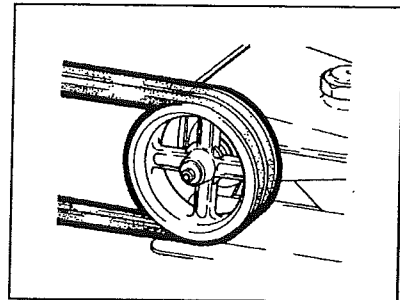

12 Wash up with the clean water after spraying.

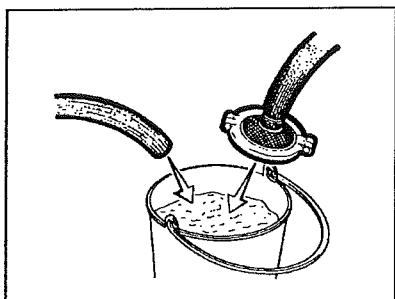

13 Running the Power Sprayer.

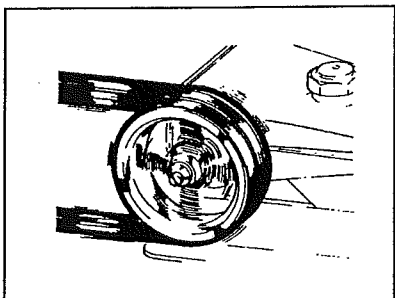

14 Continue to run the sprayer for one minute after raising the strainer.

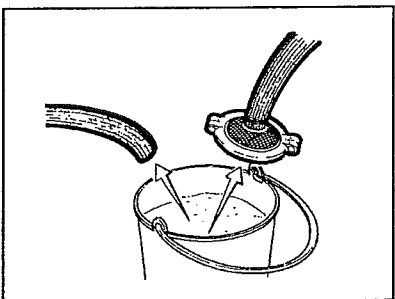

Caution!!

Running the sprayer for more than one minute without the presence of liquid may cause severe pump damage!

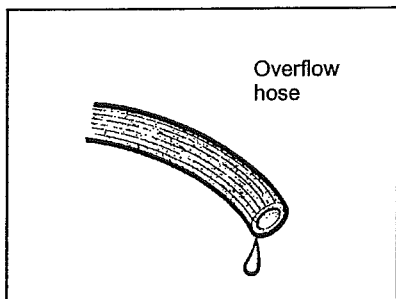

Overflow hose

15 Stopping the operation.

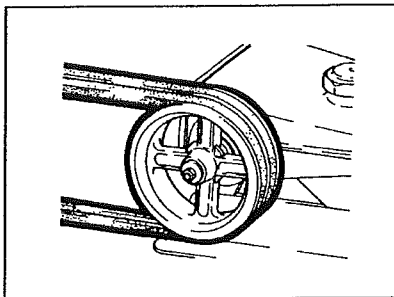

16 Detach the suction hose and overflow hose.

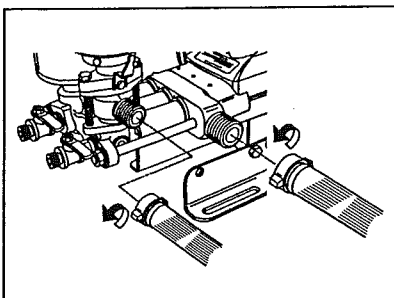

17 Resume knob to 0 position.

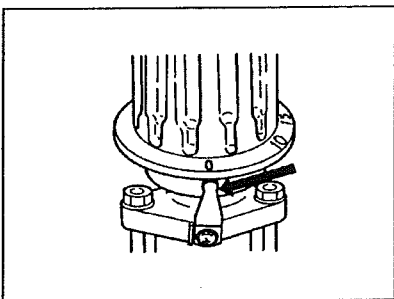

Protection from freezing.

Water should be completely drained during winter storage to prevent freezing. The operation is performed according to items from 11 to 18 in the operation procedure.

Inspection and adjustment

Discharge valve and its vicinity.

Inspect discharge valve and valve seat for wearing degree over their contact surface. Replace worn or spoiled ones, if any.

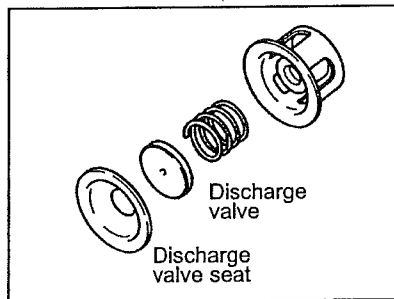

Discharge valve

Discharge valve seat

Piston and its vicinity.

Inspect parts as exploded for damage wear break, etc. Lubricate mobile oil over piston packing when reassembled.

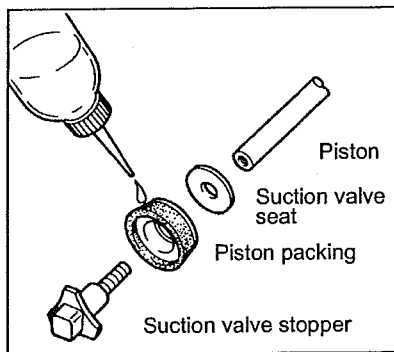

Piston

Suction valve seat

Piston packing

Suction valve stopper

Replacement of Crankcase oil.

Replace at 50 hours operation after initial operation.

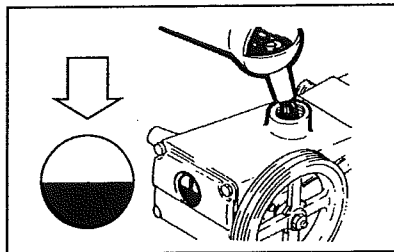

Precautions

Thank you very much for your purchase this time. Needless to say, no matter how excellent the quality of the product may be it won't display its maximum potential performance unless operated properly. Read this instruction manual repeatedly prior to operation in order to make the best use of the product. Power sprayers are for agricultural or irrigation uses and not for industrial use. Therefore, do not use chemicals, seawater, hot water, etc. When agricultural chemicals are used, read and follow the instruction manual for chemicals. For further information or assistance, please contact the nearest authorized Maruyama Dealer of the store which you purchased this product from.

When pump fails to suck liquid.

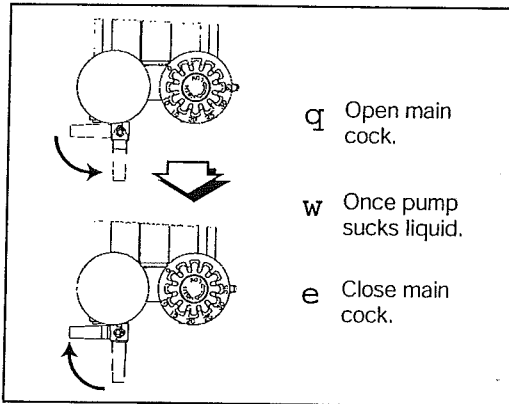

When hoses are vibrating themselves...

Hose vibration occurs when air is released out of air-chamber. It will stop if you let air send forth as following procedural.

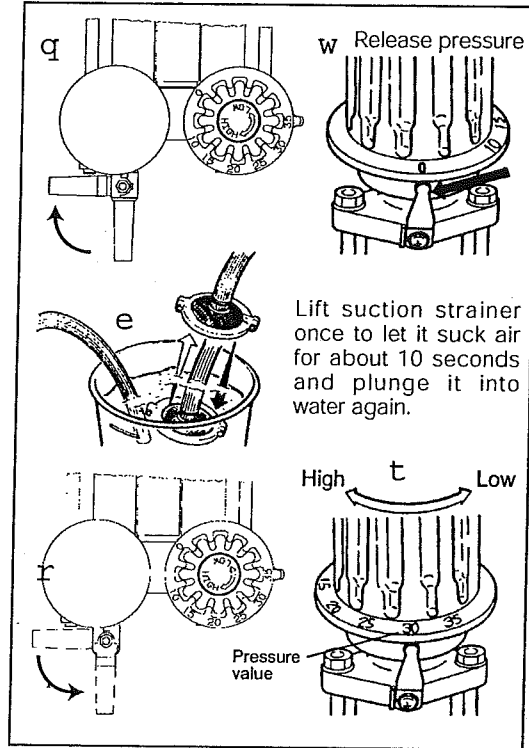

When pressure fails to get accumulated...

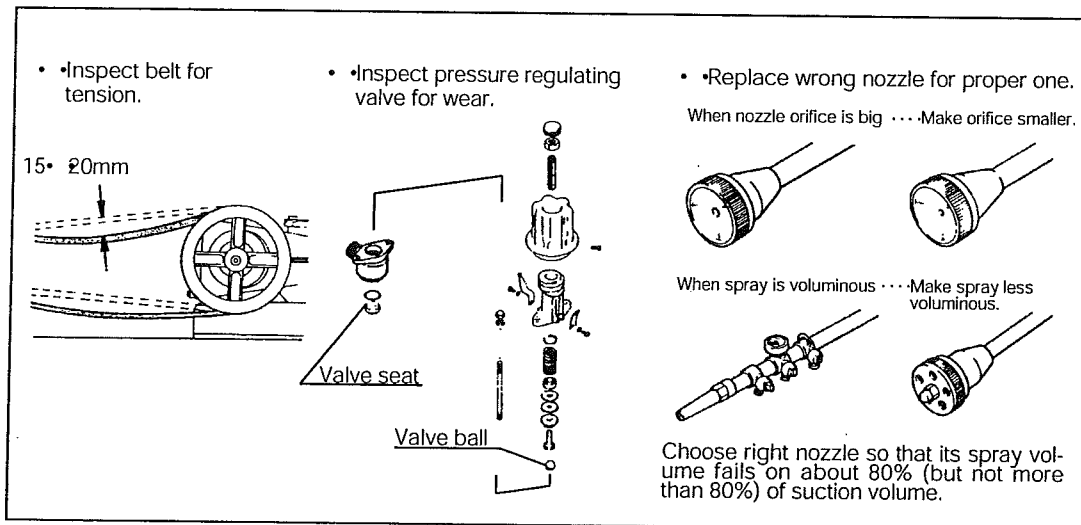

Nomenclature des pièces principales

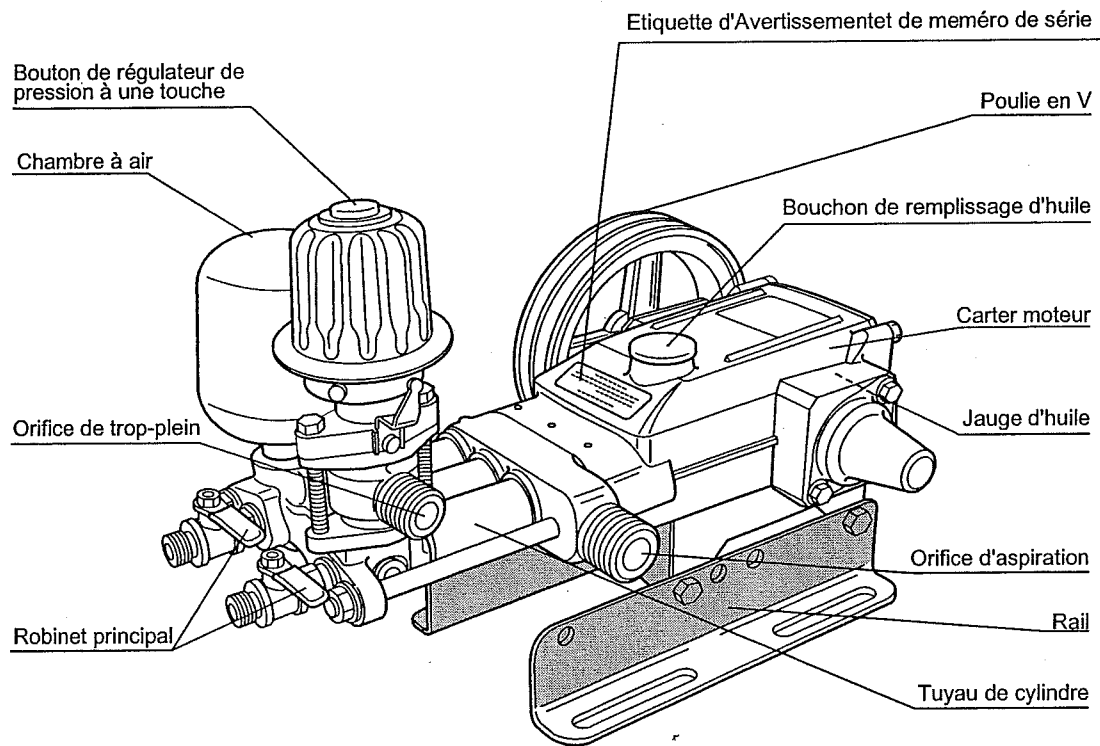

Spécifications

Modèle		MS154		MS330		
Hauteur hors-tout	Longueur hors-tout (mm)	374		399		
	Largeur hors-tout (mm)	215		243		
	Hauteur hors-tout (mm)	286		279		
Poids (kgf)		7.2		7.2		
		maximum	Irrigation	maximum	Irrigation	
Spécifications	Vitesse du vilebrequin (tr/mn)	1000	1400	1050	1300	
	Capacité d'aspiration (N/min)	13	17.5	30	35	
	Pression	MPa	3.5	1.0	3.5	2.5
		(kgf/cm ²)	(35)	(10)	(35)	(25)
Puissance requise	kw	1.0	0.5	2.0	1.9	
	(PS)	(1.4)	(0.7)	(2.8)	(2.6)	
Tuyau d'aspiration		ø13, G ¹ / ₂ (PF ¹ / ₂)		ø19, G ³ / ₄ (PF ³ / ₄)		
Tuyau de trop-plein		ø13, G ¹ / ₂ (PF ¹ / ₂)				
Robinet principal		2-G ¹ / ₄ , (2-PF ¹ / ₄)				
Huile de graissage		SAE10W-30, SC or mieux				
Contenance d'huile de graissage (l)		0.23		0.42		

Courbe de performances

MS154

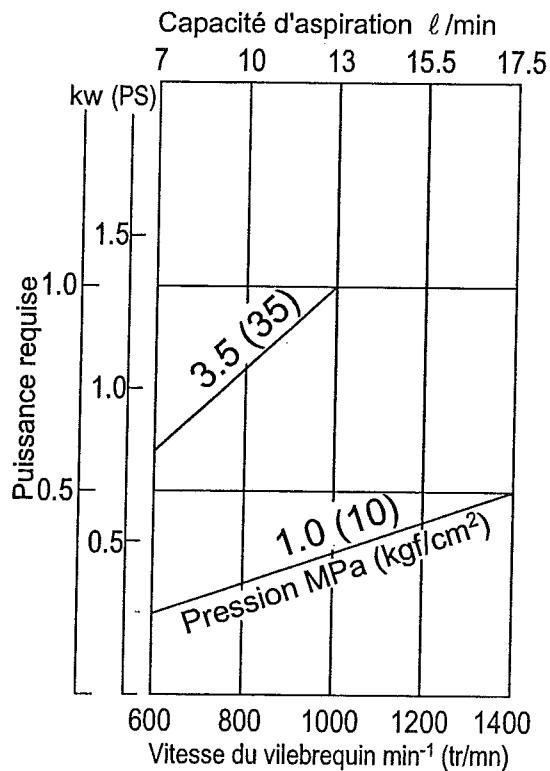

MS330

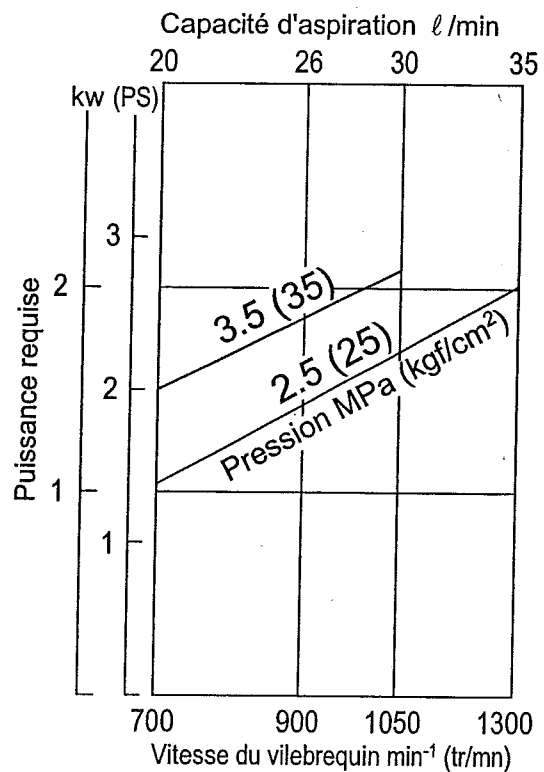

Utilisation

Inspection préparatoire
 • Vaporisation

Bien vérifier le serrage de toutes les vis.

1 Huile de graissage

Remplir le carter moteur d'huile de graissage jusqu'au niveau central de la jauge.

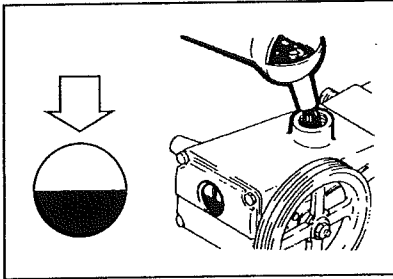

2 Graissage

Verser quelques gouttes d'huile dans les 3 orifices du carter moteur.

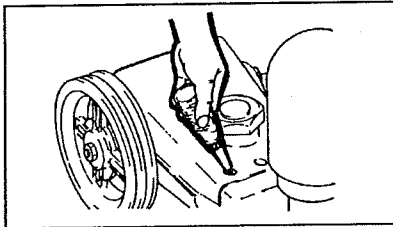

3 Installation du tuyau d'aspiration et du tuyau de trop-plein

Au cours de l'installation du tuyau d'aspiration, vérifiez d'abord la présence ainsi que le bon état des joints d'étanchéité aux abords des couplages de fils électriques.

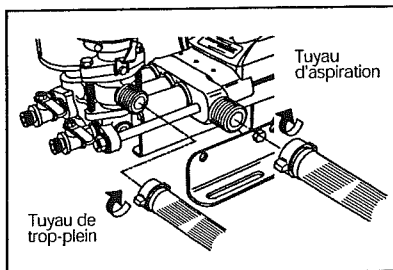

4 Fixation de la crépine pour le raccordement des tuyaux.

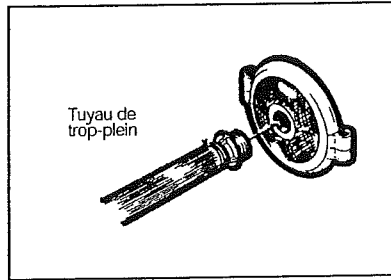

5 Insérer le tuyau d'aspiration et le tuyau de trop-plein dans le réservoir chimique.

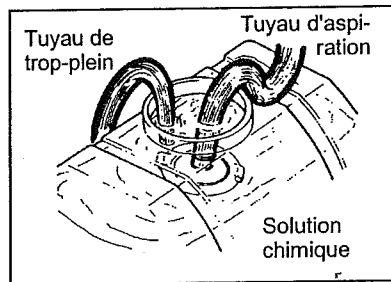

6 Régler le bouton du régulateur de pression sur 0.

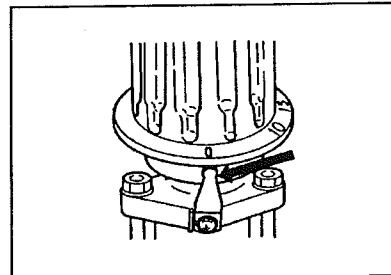

7 Refermer la soupape.

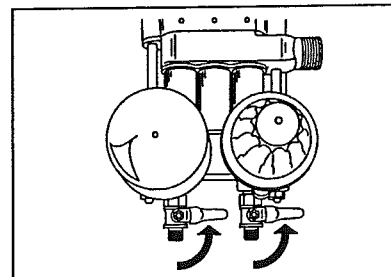

8 Mise en route

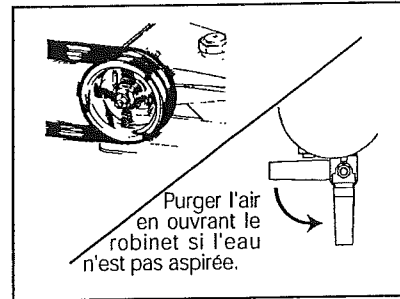

9 Régulation de la pression.

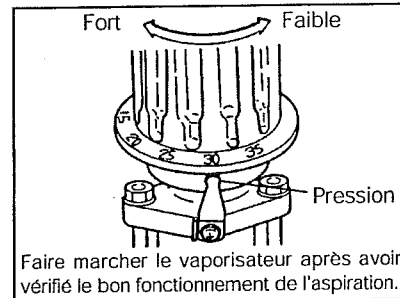

10 Vaporisation

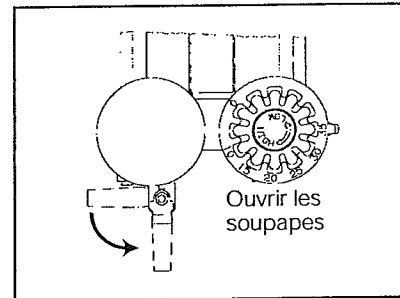

Arrêt du vaporisateur et entretien

11 Arrêt de la vaporisation

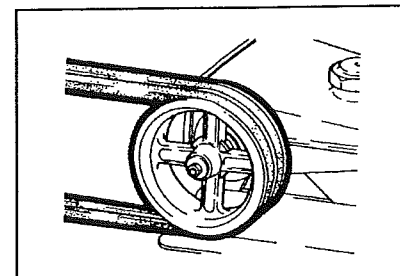

12 Laver à l'eau propre lorsque la vaporisation est terminée..

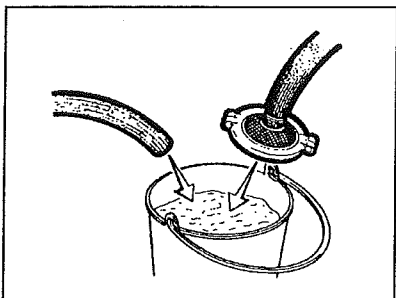

13 Utilisation du vaporisateur automoteur.

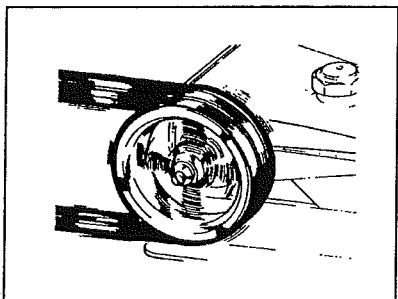

14 Continuer à faire fonctionner le pulvérisateur pendant une minute après avoir relevé la trémie.

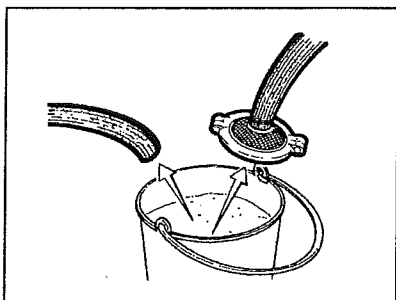

Attention !!

Faire fonctionner le vaporisateur pendant plus d'une minute en l'absence de liquide dans le réservoir peut entraîner des dégâts sévères!

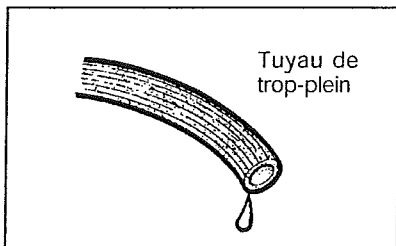

15 Fin de la vaporisation.

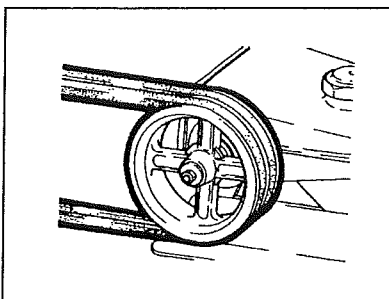

16 Retirer le tuyau d'aspiration et le tuyau de trop-plein.

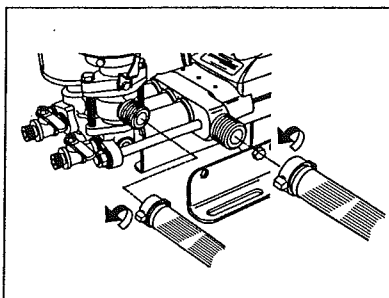

17 Ramener le bouton sur la position 0.

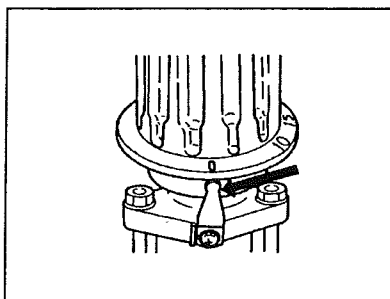

Protection contre le gel.

Vidanger complètement l'eau lors du remisage d'hiver pour éviter tout gel. Pour la vidange, effectuer les opérations 11 à 18 de la procédure.

Inspection et réglages

Soupape de refoulement et alentours

Vérifier le degré d'usure des surfaces de contact de la soupape de refoulement et du siège de soupape. Le cas échéant, remplacer les pièces usées ou endommagées.

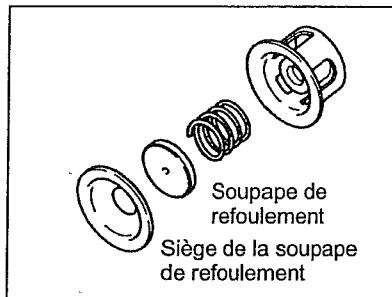

Piston et alentours

Vérifier si les pièces de l'éclaté sont endommagées, usées, cassées, etc. Lors du remontage, enduire la garniture du piston d'huile mobile.

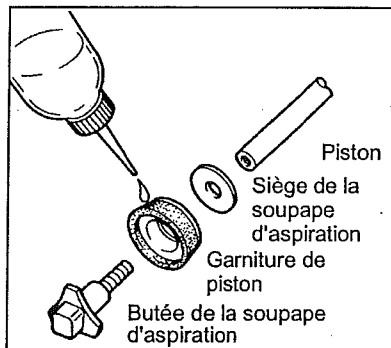

Remplacement de l'huile du carter moteur

Remplacer l'huile toutes les 50 heures d'utilisation après l'utilisation initiale.

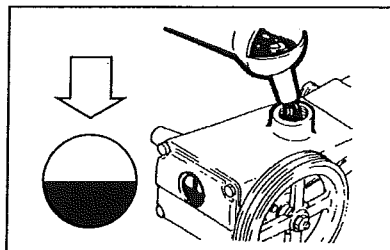

Précautions

Nous vous remercions de votre achat. Il va sans dire que, le produit aura beau être d'une excellente qualité, il ne déploiera pas le maximum de ses performances s'il n'est pas utilisé correctement. Lisez plusieurs fois ce manuel avant de mettre l'appareil en service afin d'en tirer le maximum de profit.

Les vaporisateurs automoteurs sont conçus à des fins agricoles ou d'irrigation et non à des fins industrielles. En conséquence, n'utilisez pas de produits chimiques, eau de mer, eau chaude, etc. Quand vous utilisez des produits agrochimiques, lisez attentivement leur mode d'emploi et suivez-le.

Pour de plus amples informations, veuillez vous adresser au revendeur agréé Maruyama le plus proche, ou bien vous renseigner auprès du magasin où vous avez acheté ce produit.

Si la pompe n'aspire pas le liquide

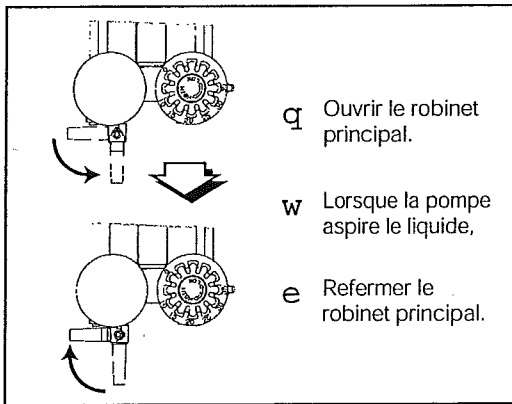

Si les tuyaux vibrent ...

Les tuyaux vibrent lorsque l'air est rejeté de la chambre à air. Les vibrations cesseront dès que l'air sera relâché comme suit.

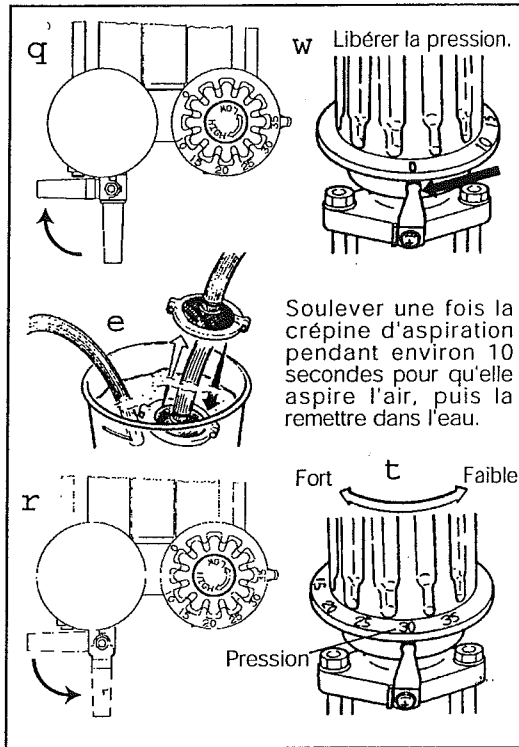

Si l'accumulation de pression ne s'effectue pas...

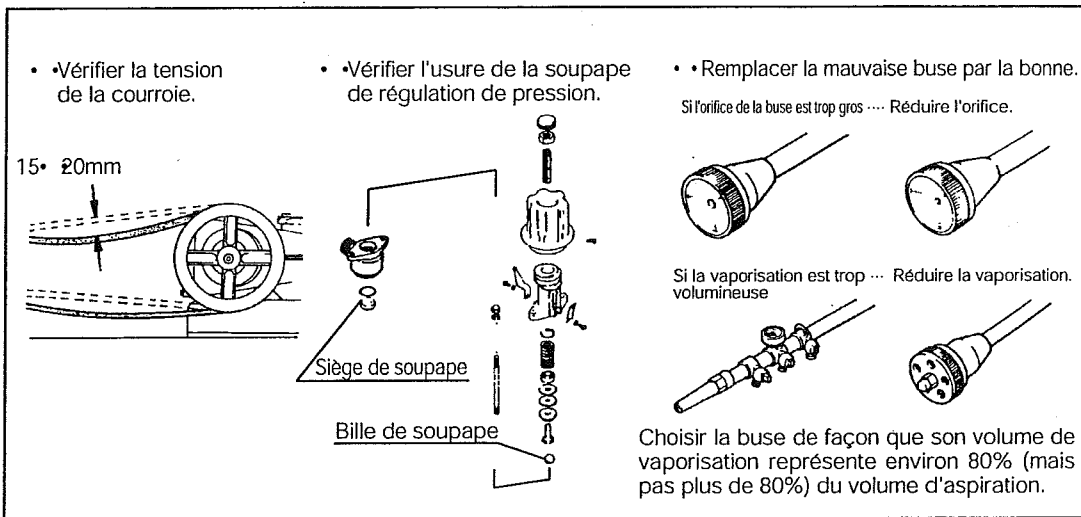

Nomenclatura de piezas principales

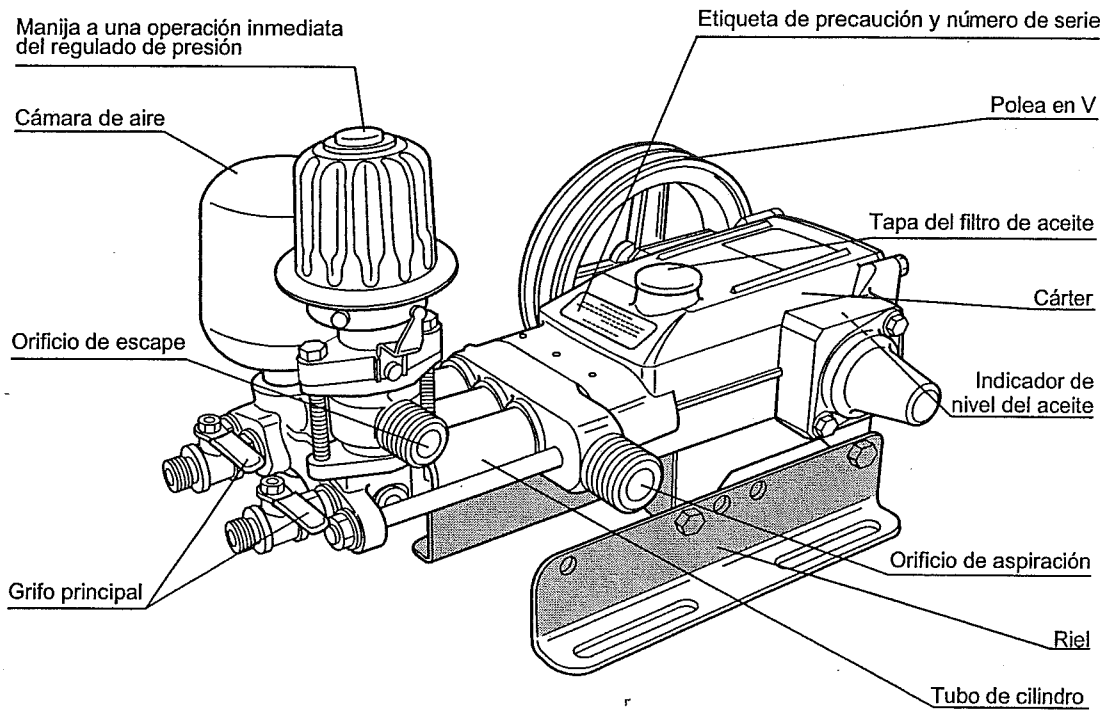

Especificaciones

Modelo		MS154		MS330		
Altura total	Longitud total (mm)	374		399		
	Anchura total (mm)	215		243		
	Altura total (mm)	286		279		
Peso (kgf)		7.2		7.2		
		Máximo	Irrigación	Máximo	Irrigación	
Especificaciones	Velocidad del cigüeñal (rpm)	1000	1400	1050	1300	
	Capacidad de aspiración (ℓ/min)	13	17.5	30	35	
	Presión	MPa	3.5	1.0	3.5	2.5
		(kgf/cm ²)	(35)	(10)	(35)	(25)
Potencia requerida	kw	1.0	0.5	2.0	1.9	
	(PS)	(1.4)	(0.7)	(2.8)	(2.6)	
Manguera de aspiración		ø13, G ¹ / ₂ (PF ¹ / ₂)		ø19, G ³ / ₄ (PF ³ / ₄)		
Manguera de escape		ø13, G ¹ / ₂ (PF ¹ / ₂)				
Grifo principal		2-G ¹ / ₄ , (2-PF ¹ / ₄)				
Aceite lubricante		SAE10W-30, SC or mejor				
Capacidad del aceite lubricante (ℓ)		0.23		0.42		

Curva funcional

MS154

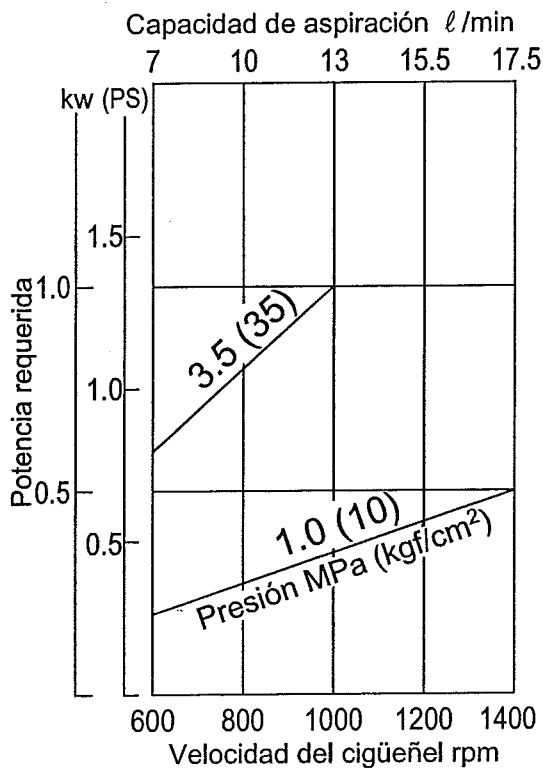

MS330

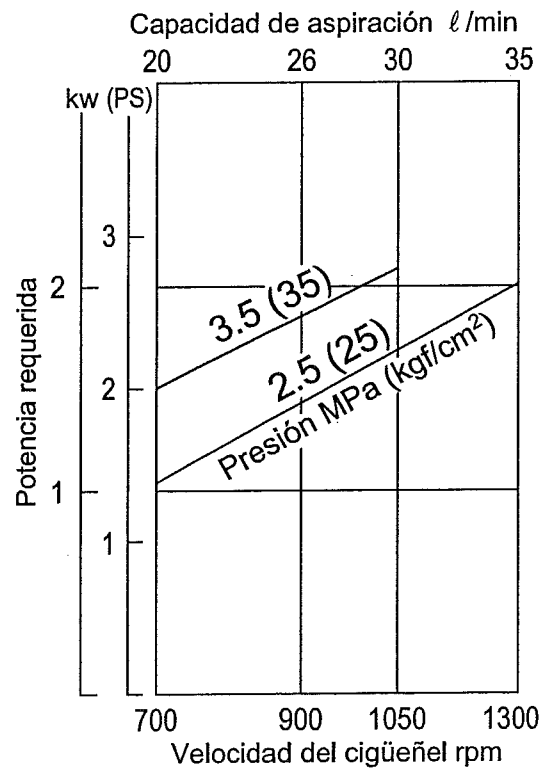

Procedimiento de operación

Inspección preparatoria
• Pulverización

Asegurarse sin falta de que todos los tornillos estén bien apretados.

1 Aceite lubricante.

Llenar el aceite lubricante en el cárter hasta el centro del indicador de nivel del aceite.

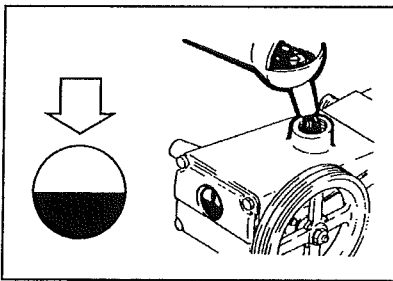

2 Lubricación

Alimentar unas gotas de aceite en los 3 orificios del cárter.

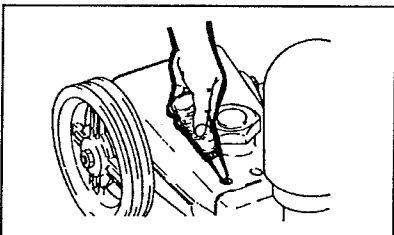

3 Instalación de la manguera de aspiración y la manguera de escape.

En la instalación de la manguera de succión, compruebe que hay juntas obturadoras en los acoplamientos rosca-dos.

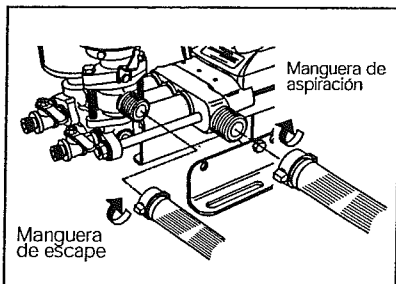

4 Conexión de la alcachofa para el acoplamiento de manguera.

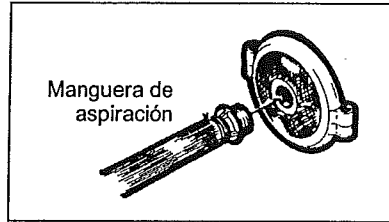

5 Insetar la manguera de escape y la manguera de aspiración en el depósito de sustancia química.

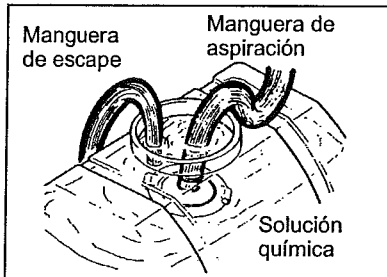

6 Ajustar la manija del regulador de presión a 0.

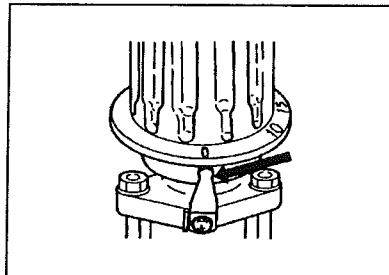

7 Cerrar la válvula.

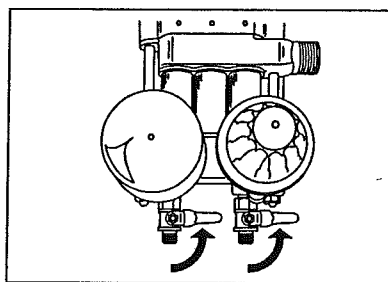

8 Arranque



9 Regulación de presión.

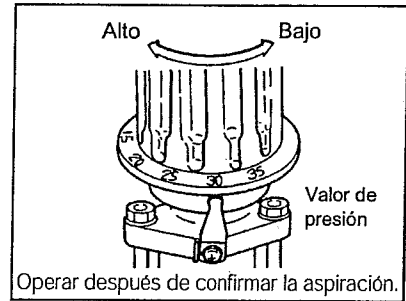

10 Pulverización

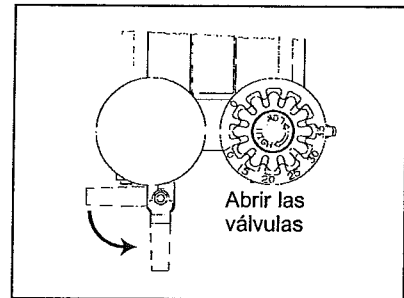

Parada de operación y
mantenimiento

11 Parada de pulverización

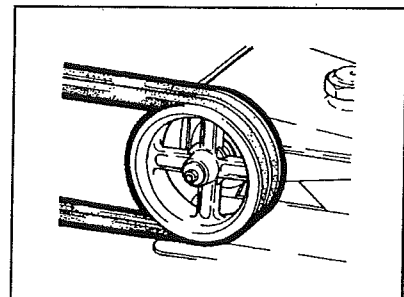

12 Lavar con agua limpia después de pulverización.

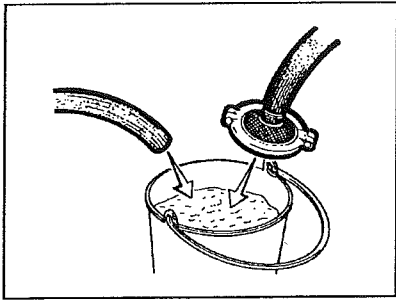

13 Puesta en funcionamiento del Power Sprayer.

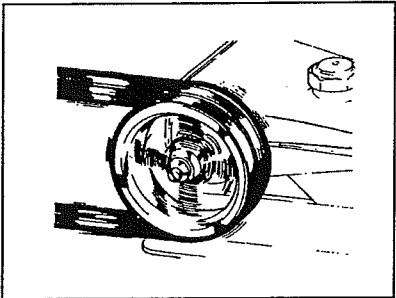

14 Continuar haciendo funcionar el Power Sprayer por un minuto después de levantar la alcachofa.

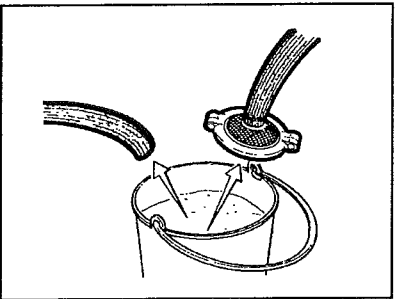

Cuidado!

La operación sin líquido del rociador por más de un minuto puede causar severa avería de la bomba!

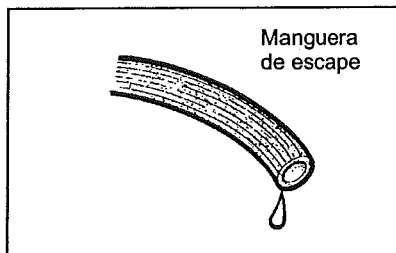

15 Parada de operación.

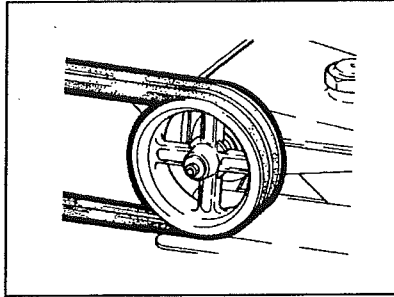

16 Separar la manguera de aspiración y la manguera de escape.

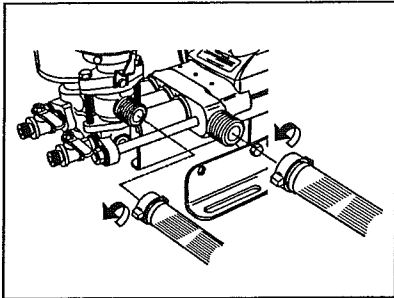

17 Reponer la manija a la posición 0.

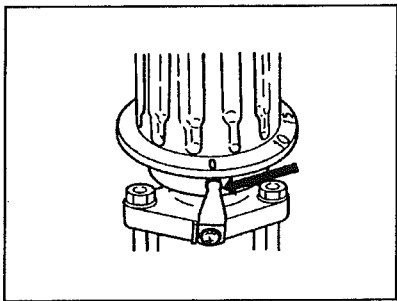

Protección contra la congelación.

El agua debe ser extraída completamente durante el invierno para prevenir la congelación. La operación relativa se efectúa según los elementos 11-18 indicados en el procedimiento de la operación.

Inspección y ajuste

Válvula de descarga y su entorno.

Inspeccionar la válvula de descarga y el asiento de la válvula para ver si la superficie de contacto de ambas partes está excesivamente desgastada. Reemplazar las piezas desgastadas o deterioradas, si las hay.

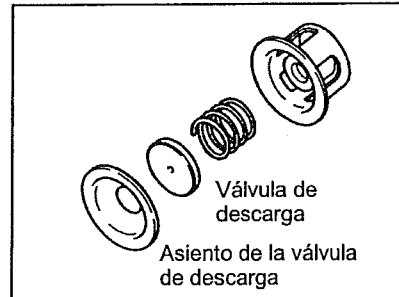

Pistón y su entorno.

Inspeccionar las piezas indicadas en la vista desarrollada para ver si están dañadas, desgastadas, rotas, etc. Lubrificar la guarnición estanca del pistón con aceite fluido al rearmarla.

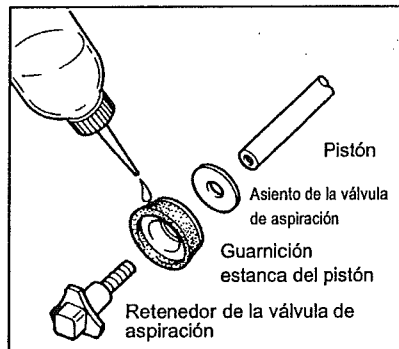

Reemplazo del aceite del cárter

Reemplazar el aceite después de 50 horas a partir de la operación inicial.

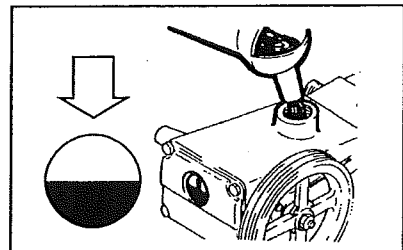

Precaución

Muchas gracias por haber comprado nuestro producto. Excusado es decir que, por más excelente que sea la calidad del producto, eso no podrá mostrar su funcionamiento potencial al máximo a menos que lo haga funcionar correctamente. Para sacar el mejor provecho del producto, leer repetidamente este manual de instrucciones antes de comenzar las operaciones.

Power sprayers son para uso agrícola o de irrigación y no para uso industrial. Por lo tanto no usar sustancias químicas, agua de mar, agua caliente, etc. Cuando se usan sustancias agriquímicas, leer y seguir el manual de instrucciones para sustancias químicas.

Para mayor información o asistencia, sírvase ponerse en contacto con el Agente Autorizado de Maruyama o el establecimiento donde adquirió este producto.

Cuando la bomba no aspira líquido.

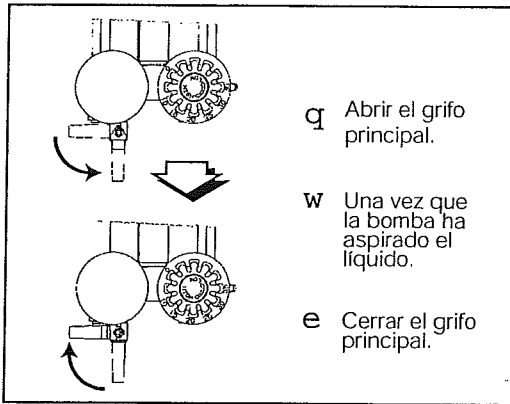

Cuando las mangueras vibran solas...

La vibración de mangueras ocurre cuando el aire se escapa de la cámara de aire. Para detener esto seguir el procedimiento siguiente y mandar fuera el aire.

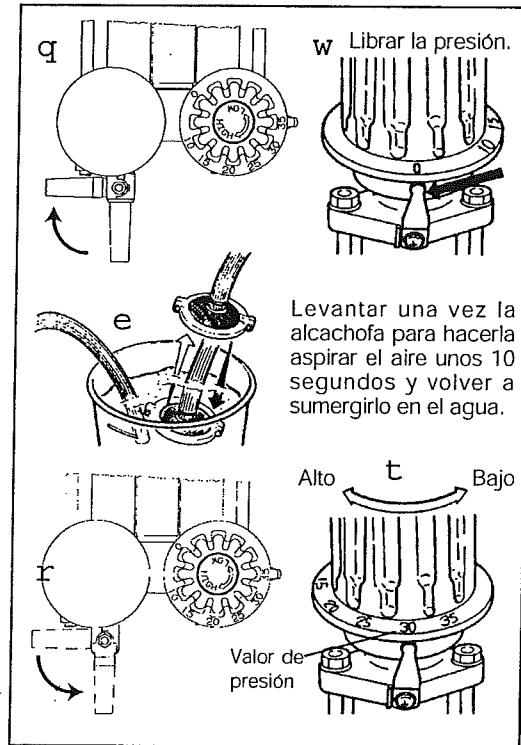

Cuando la presión no se acumula...

