

Introduction

Thank you for purchasing our Full Cabin for BSA-650/950.

This Operation Manual explains the BSA650/950 cabin specification machine: unique handling procedures and how to carry out simple inspection and care. For other explanations, please refer to the separate operation manual. Before using the product, read this Operation Manual and the operation manual of this BSA machine carefully to ensure their correct use. After reading the manuals, keep them in a convenient place so that they can be referenced at any time.

■ Precautions

In this Operation Manual, handling precautions that are considered particularly important are accompanied by the following symbols:

 **Danger** --- Failure to follow this instruction will lead to death or serious injury.

 **Warning** --- Failure to follow this instruction may lead to death or serious injury.

Caution --- Failure to follow this instruction may lead to machine damage.

■ For Safe Work

- Before commencing work, read the “For Safe Work” chapter in this Operation Manual and the Safety Manual carefully and follow the instructions to carry out your work safely.

■ International Units

This Operation Manual uses international units. Carefully read the table below to understand the conversion values before use.

Conversion Table

Item	Unit indication under new measuring system	Conversion	Conventional unit indication	Remarks
Area	[m ²] (square meters) [a] (are) [ha] (hectare)	10000 [m ²] = 1 [ha] = 100 [a] = 10 tanbu = 3,000 tsubo	[a] (are) [ha] (hectare) Tsubo, chobu, tanbu	*[1]
Rotational speed	[rpm] (revolutions per minute) [min ⁻¹] (per minute)	1 [min ⁻¹] = 1 [rpm]	[rpm]	*[2]
Force	[N] (Newton)	9.8 [N] = 1 [kgf]	[kgf] (weight kilogram)	
Moment of force	[N·m] (Newton meter)	9.8 [N·m] = 1 [kgf·m]	[kgf·m]	
Pressure	[Pa] (Pascal)	0.98 [MPa] = 10 [kgf/cm ²] 9.8 [Pa] = 1 [mmH ₂ O]	[kgf/cm ²] [mmH ₂ O]	
Work ratio/ drive power	[W] (watt)	735.5 [W] = 1 [PS] 9.8 [W] = 1 [kgf·m/s]	[PS] [kgf·m/s]	

* Notes

[1] [a] and [ha] may be used to indicate land areas.

[2] The number of revolutions per unit time is indicated as “rotational speed” not as “revolutions.”

Table of Contents

▲ Safety Precautions	4
▲ Handling of Warning Labels	5
Cabin Equipment	
Opening/Closing the Door/Rear Window.....	6
Wiper/Washer Switch.....	7
Room Lamp	7
Air Conditioner	8
Rearview Mirror	11
Driver's Seat	
Brake Pedal	12
Accelerator Pedal.....	12
Differential Lock Pedal	12
Parking Brake	12
Entry/Exit Procedures	13
Inspection/Maintenance	
List of Locations Requiring Periodic Inspection.....	14
Irregular Inspection/Maintenance.....	14
200-hour Inspection/Maintenance	15
Annual Inspection/Maintenance	15

Safety Precautions

Warning

- Do not bring into the cabin any container carrying pesticide or object to which pesticide is attached. It may cause poisoning.
- Do not smoke inside the cabin. It may cause fire.

Reference

- The cabin significantly reduces the operator's exposure to pesticide, but it cannot fully prevent exposure. It is recommended that you wear a pesticide mask when spraying pesticide.
- The air filters installed in the cabin cannot shut off unpleasant smell coming from the outside.

Handling of Warning Labels

* Warning labels are attached on this machine. Carefully read these labels and understand the contents before commencing work. Peruse the following information provided on the labels.

Warning

- Constantly remove soiling and mud over the labels so that the information provided on them remains clearly visible.
- Replace damaged warning labels with new ones.
- If a part on which a warning label is attached has been replaced, be sure to attach a new label on the new part at the same location.

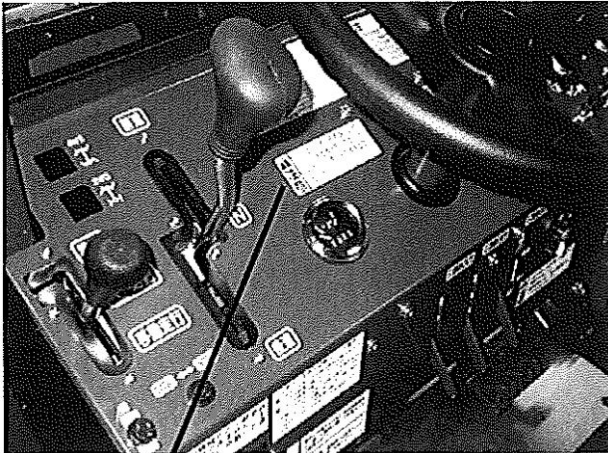

Part No. 176775

 Caution	<ul style="list-style-type: none">● When actuating the differential lock, keep the steering wheel in the straight-moving position.● Do not turn with the differential lock engaged.
	P./N. 176775

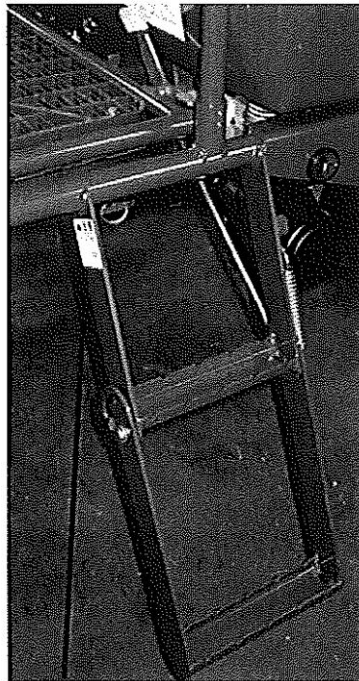

Part No. 533042

 Caution
Do not bring hands or objects closer to the machine to prevent pinching.
533042

Cabin Equipment

Opening/Closing the Door/Rear Window

Warning

- Do not carry objects in the cabin as they may damage the glass.
- Do not keep the door open, because the door may close unintentionally due to strong wind or gravity on the slope, causing injury.
- When closing the door/rear window, be sure to close it securely and fully.

Caution

- When closing the door/rear window, be careful not to pinch your fingers or parts of your body.

Caution

- Do not travel or move on rough road with the rear window open.
- Do not force open the door/rear window beyond their operating range.

Door

Tilt the door lever in the direction of the arrow to unlock and open the door.

Rear Window

Turn the door lever in the clockwise direction and press the lever. The damper will function to open the rear window.

(Outside of door)

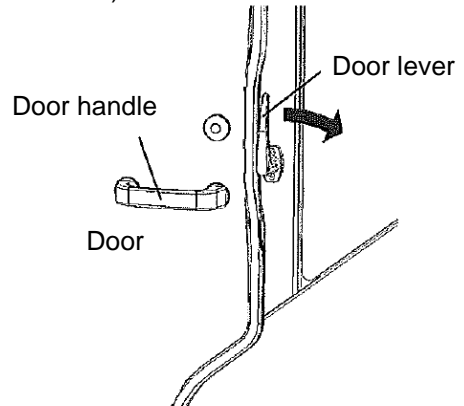

(Inside of door)

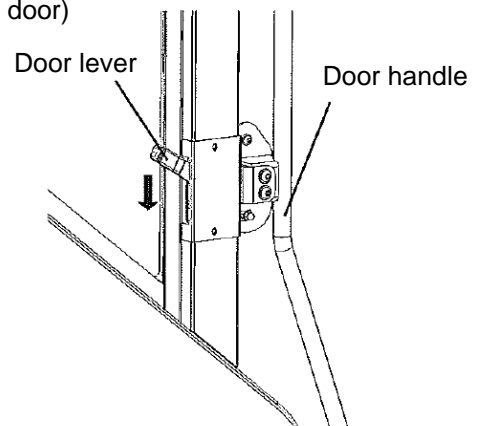

(Rear window)

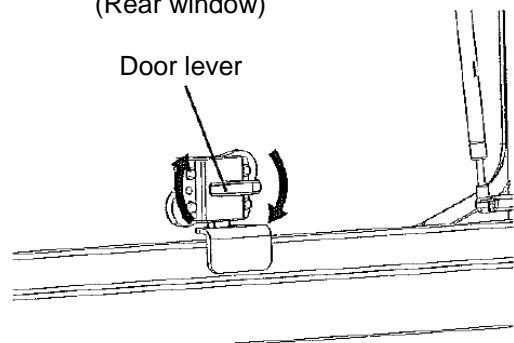

Cabin Equipment

Room Lamp

Regardless of whether the door is open or closed, turning "ON" the room lamp switch turns on the lamp, while turning "OFF" the switch turns off the lamp.

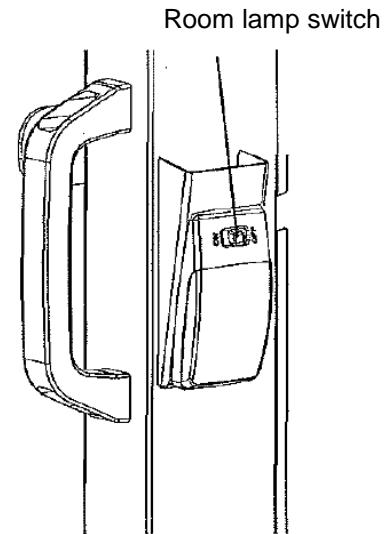

Wiper/Washer Switch

Caution

- If the wiper rubs the glass dry, the glass may be damaged. Be sure to spray washer fluid before operating the wiper.
- If frost, snow or other foreign object is attached to the glass, the windshield glass or wiper motor may be damaged.
- If necessary, remove snow or ice from the windshield and wiper before travelling.
- In cold weather, the wiper blade may stick to the glass due to icing. If the wiper is operated in this condition, the wiper blade and wiper motor may break down. Be sure to turn "OFF" the key switch, remove ice, and then restart the wiper.

Press the switch to operate the wiper. Press and hold the switch, and washer fluid will be sprayed as the wiper operates, but only while the switch is held.

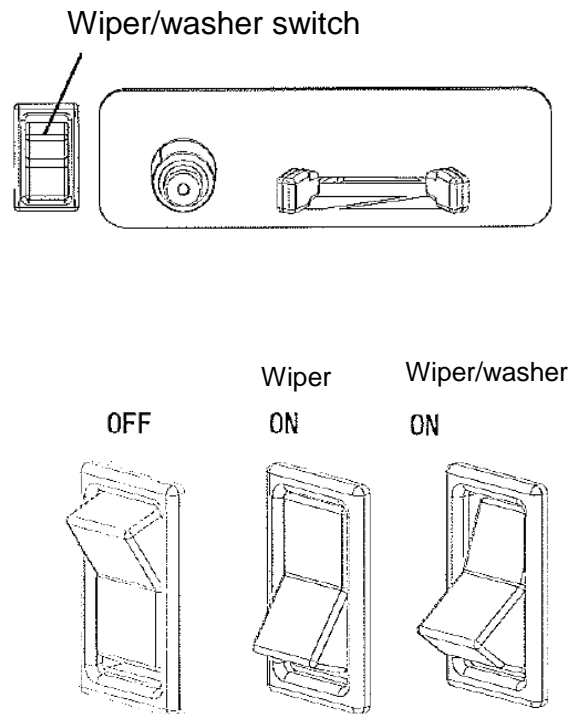

Cabin Equipment

Air Conditioner

Warning

- So as to ensure a clear view of the outside, make sure all window and windshield glasses are free from frost, snow or fogging.
- Take heed to use the heater/air conditioner correctly to ensure good visibility.

Temperature Control Lever

This lever is used to adjust the temperature. Slide the lever to set a desired temperature. Cold air is released when the lever is at the far left position, while hot air is released when it is at the far right position.

Fan Switch

You can turn the knob to switch the fan speed to one of three levels: LO, ME and HI. HI corresponds to the highest fan speed.

Air Conditioner Switch

Press the button to turn ON/OFF the air conditioner system. The indicator lamp is lit while this switch is "ON."

Important

- When using the work lamp, air conditioner and other electrical systems and equipment, operate the engine at the maximum speed; otherwise, the battery will die.

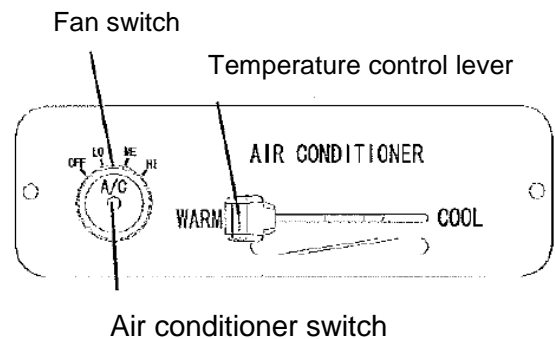

Cabin Equipment

Air Outlet

- Never close the air outlets fully so that heating/cooling will work to full capacity and air will be taken into the cabin.
- To adjust the direction of air, use the lever at the outlet to move the levers up/down and to the left/right.
- When running the air conditioner in the defrosting (glass defogging) mode, orient the front windshield air outlets and side (door) air outlets toward the glass.

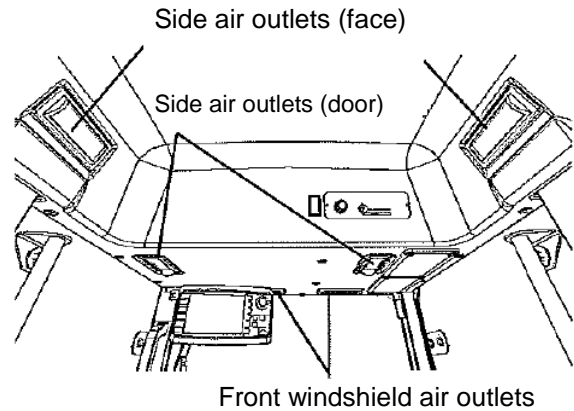

Recirculation Mode

Warning

- **Do not use the recirculation mode for an extended period of time as it prevents fresh air from entering the cabin.**
 - **Do not use the recirculation mode unless necessary.**
- Outside air does not enter when the lever is tilted to the recirculation side.
 - If the outside air temperature is extremely high or low, the cabin can be cooled or heated more quickly by selecting the recirculation mode temporarily.

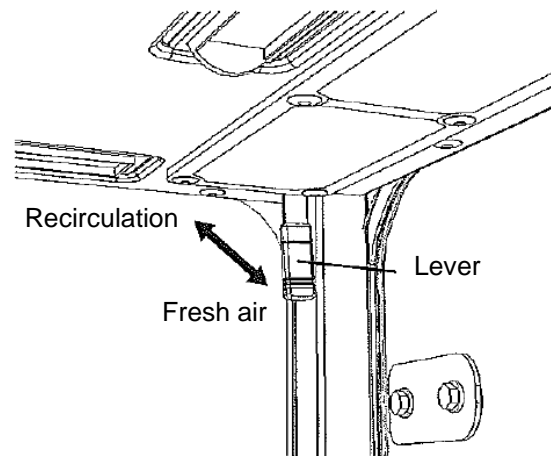

Cabin Equipment

Heater

- If the engine does not reach the operating temperature, the maximum heating capacity cannot be demonstrated and the windows/windshields cannot be defrosted quickly.
- Since the heater has no cooling or dehumidifying function, the cabin temperature cannot be set lower than the outside air temperature.

1. Set to the fresh air mode.
2. Set the fan switch to LO or ME.
3. Set the temperature control lever to the center position.
4. Open and adjust the air outlets.

Caution

- **In winter, use antifreeze agent at a concentration appropriate for the outside air temperature. Do not use expired antifreeze agent.**
- **Replace the water hose every 2 seasons.**

Cabin Equipment

Cooling

- The air conditioner system in the cabin operates when the fan switch is turned on while the engine is running.
- Close the windows for effective cooling. If the machine has been parked under the direct sun and the cabin is hot, keep the windows open for a while to let the cabin cool faster.

1. Set to the fresh air mode.
2. Turn on the fan switch (LO, ME or HI).
3. Press the air conditioner switch to turn it "ON."
4. Adjust the temperature control lever to the "COOL" or center position and set a comfortable temperature.
5. Open and adjust the air outlets.

Reference

- **If the outside air temperature and humidity are high, water droplets may be discharged from the evaporator of the cooling system and water may collect below the machine. This is normal and should not be confused with leakage.**

Defrosting (Defogging of Glass)

1. Set to the fresh air mode.
2. Set the fan switch to "HI."
3. Turn "ON" the air conditioner switch.
4. Orient the front windshield air outlets and side air outlets (door) toward the glass.

Rearview Mirror

The rearview mirror angle can be adjusted up/down or to the left/right, so sit in the driver's seat and adjust the mirror to an easy-to-view position.

Driver's Seat

Brake Pedal

Step on the brake pedal to stop the vehicle.

Reference

- The structure of the brake pedal is such that when the pedal is stepped on, the clutch is disengaged first and then brake is applied. To apply brake, depress the brake pedal fully.

Accelerator Pedal

While travelling, adjust the engine speed with the accelerator pedal. Step on the accelerator pedal to raise the engine speed, or release the pedal to let the engine run idle.

Differential Lock Pedal

Use this pedal when one wheel slips on soft ground, etc. The differential gear in the axle remains locked while the differential lock pedal is depressed, to prevent the wheel from slipping on the side.

Caution

- Avoid operating the differential lock when turning. Wheel speed difference with respect to the inner wheel will quicken the wear and damage of the equipment.

Parking Brake

Depress the brake pedal fully and then pull up the parking brake lever and hook it on the brake pedal. To release the parking brake, step on the brake pedal.

Caution

- When leaving the vehicle, stop the engine, apply the parking brake without fail, pull out the key, and lock the tires.

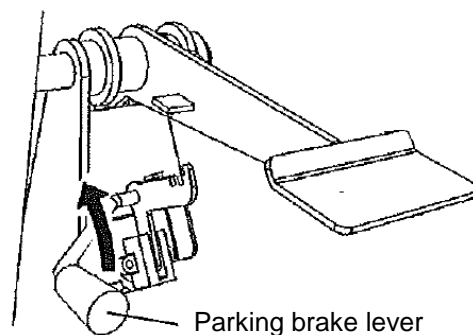
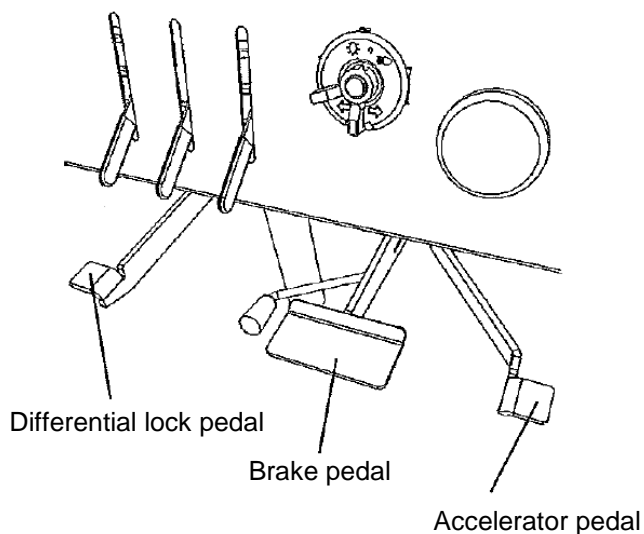

Entry/Exit Procedures

Enter/exit the machine using the passenger steps at the rear.
The passenger steps can be stored. Use them as necessary.

(How to Store)

Step on the pedal (store) to store the passenger steps.

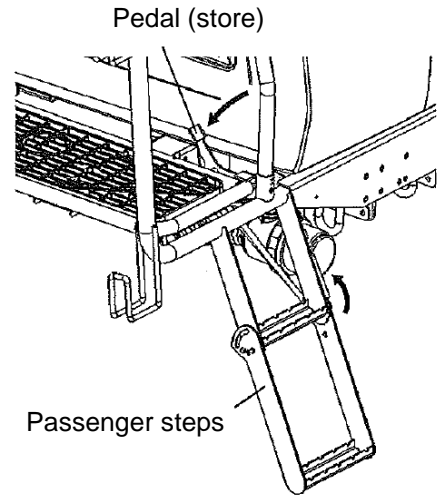

(How to Extend)

Step on the pedal (extend) to extend the
passenger steps.

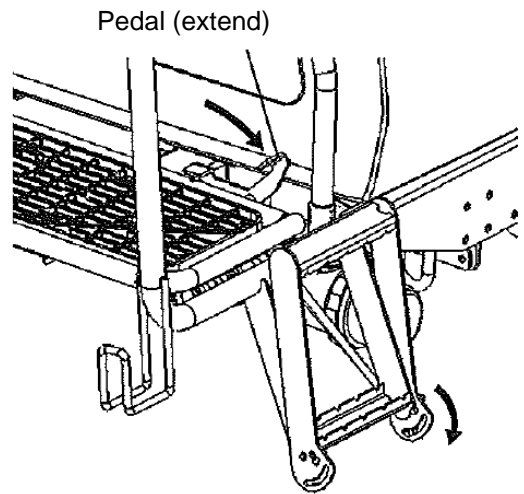

Inspection/Maintenance

List of Locations Requiring Periodic Inspection

Interval (time)	Item	Description
Irregular (as necessary)	Washer fluid	Replenish
	Lubrication of each part	Lubricate
	Refrigerant gas level	Inspect
200 hours	Clogged interior air filter	Clean
	Clogged exterior air filter	Clean
1 year	Heater piping	Inspect
	Air conditioner piping	Inspect

Irregular Inspection/Maintenance

Replenishing Washer Fluid

Replenish automobile washer fluid as appropriate.

Caution

- Do not use pure water only in order to prevent freezing.
- Do not operate the washer system when there is no washer fluid, because the pump may be damaged.
- Keep contaminants out to prevent the washer nozzle from clogging.

Lubricating Each Part

Lubricate the door hinges and rear window hinges.

Washer tank

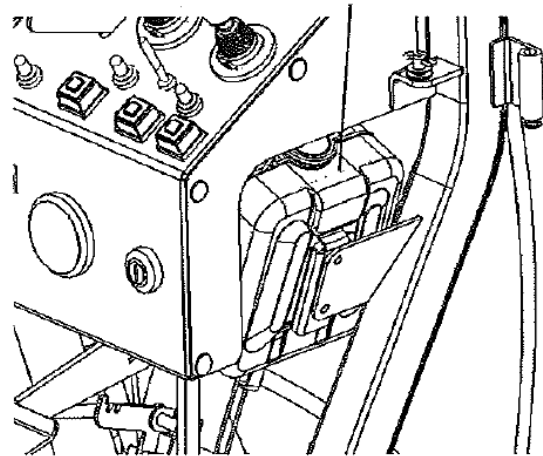

Inspection/Maintenance

Inspecting the Refrigerant (Gas) Level

If refrigerant is low, the air conditioner does not cool as it should.

Inspect the refrigerant level by following the procedure below, and if it is low, perform inspection and fill refrigerant.

(How to Inspect)

1. Operate the air conditioner under the following conditions:
Engine speed: Idling
Temperature control lever: Maximum cooling position (far right)
Fan switch: Maximum fan speed (HI)
Air conditioner switch: ON
2. Look through the sight glass in the hood to check the condition of refrigerant flowing according to the refrigeration cycle.

Appropriate: Little air bubbles are seen in the flow.

Low: Air bubbles are seen in the flow. (Air bubbles pass by continuously.)

Empty: No color, clear

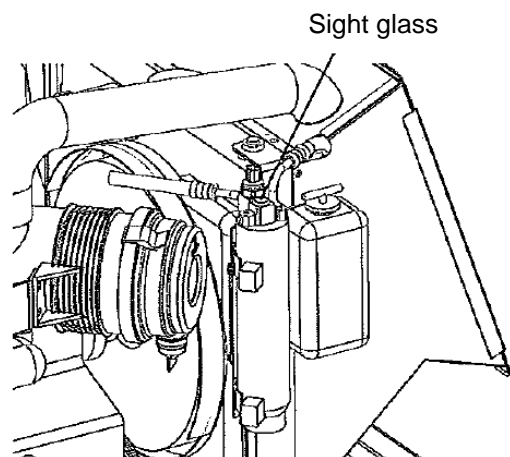

200-hour Inspection/Maintenance

Cleaning the Interior Air Filter

When the filter gets clogged, the air conditioner efficiency drops. Clean the filter to protect the filter mesh against damage.

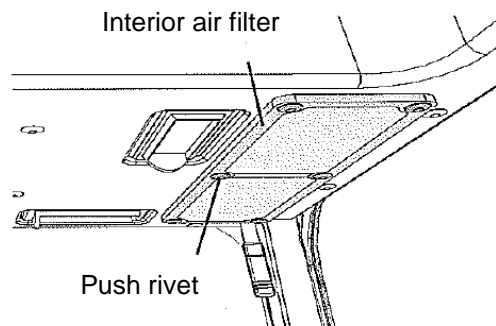

(How to Remove)

Lightly press the center of the push rivet and remove the rivet from the interior air filter.



(How to Install)

Pull out the center of the push rivet a little, insert the push rivet into the interior air filter, and press the center to lock the rivet.

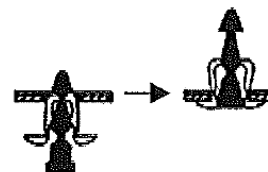

Inspection/Maintenance

Cleaning the Exterior Air Filter

Remove the exterior air filter and blow air from the direction opposite the direction of air flow.

Caution

- Do not pat the element. If the element is deformed, dust may enter the air conditioner unit and damage the air conditioner.

(How to Remove)

Remove the knob bolt and take out the cover and filter together.

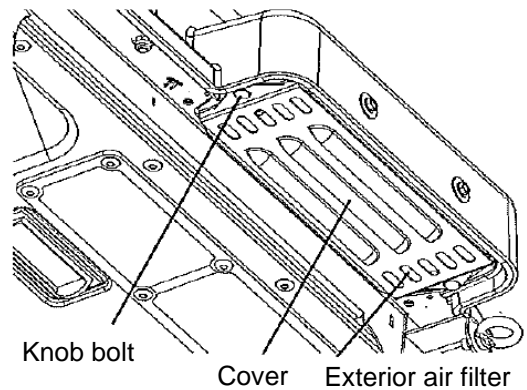

Annual Inspection/Maintenance

Inspecting the Heater Piping and Water Hose

Inspect each pipe and water hose for damage.

Inspecting the Air Conditioner Piping and Hose

Inspect each pipe and hose for damage.

Inspection/Maintenance

Other

Caution on Washing

Caution

- When washing the cabin, do not use pressurized water. Water may leak into the cabin and cause electrical components to fail.

Changing Cooling Water

The cabin specification requires a lot of cooling water because cooling water must circulate around the heater. To feed fresh cooling water when changing cooling water, fill the radiator and reserve tank to the filler port, run the engine for a while to warm the cooling water, and then stop the engine.

When the temperature drops, cooling water in the reserve tank gets suctioned in. Add cooling water to the reserve tank if the level is low at this time.

memo

memo

製品に関するお問合せ等は、まず、ご購入の販売店にご相談ください。
または、下記の全国共通の無料通話でもお受けいたします。

丸山サポートセンター

無料通話 0120-898-114

受付時間 9:00~17:00 (土、日、祝日を除く)

製品に関してお問合せいただく際は、正確にご対応させていただくため、あらかじめ下記の事項をご準備ください。

- ① 製品型式名、製造番号
- ② ご購入年月日
- ③ 販売店

 **株式会社 丸山製作所**
本社/東京都千代田区内神田3-4-15 TEL (03) 3252-2281 (営・代表) 〒101-0047

この取扱説明書の部品番号は、868642

P/N. 868642-01 2013.05