

MARUYAMA

**OPERATOR'S MANUAL
MANUEL DE L'OPÉRATEUR
Manual del Operador
BL5100/BL8200
BACKPACK BLOWER
SOUFFLEUSE À DOS
Sopladora de Cargar a la Espalda**

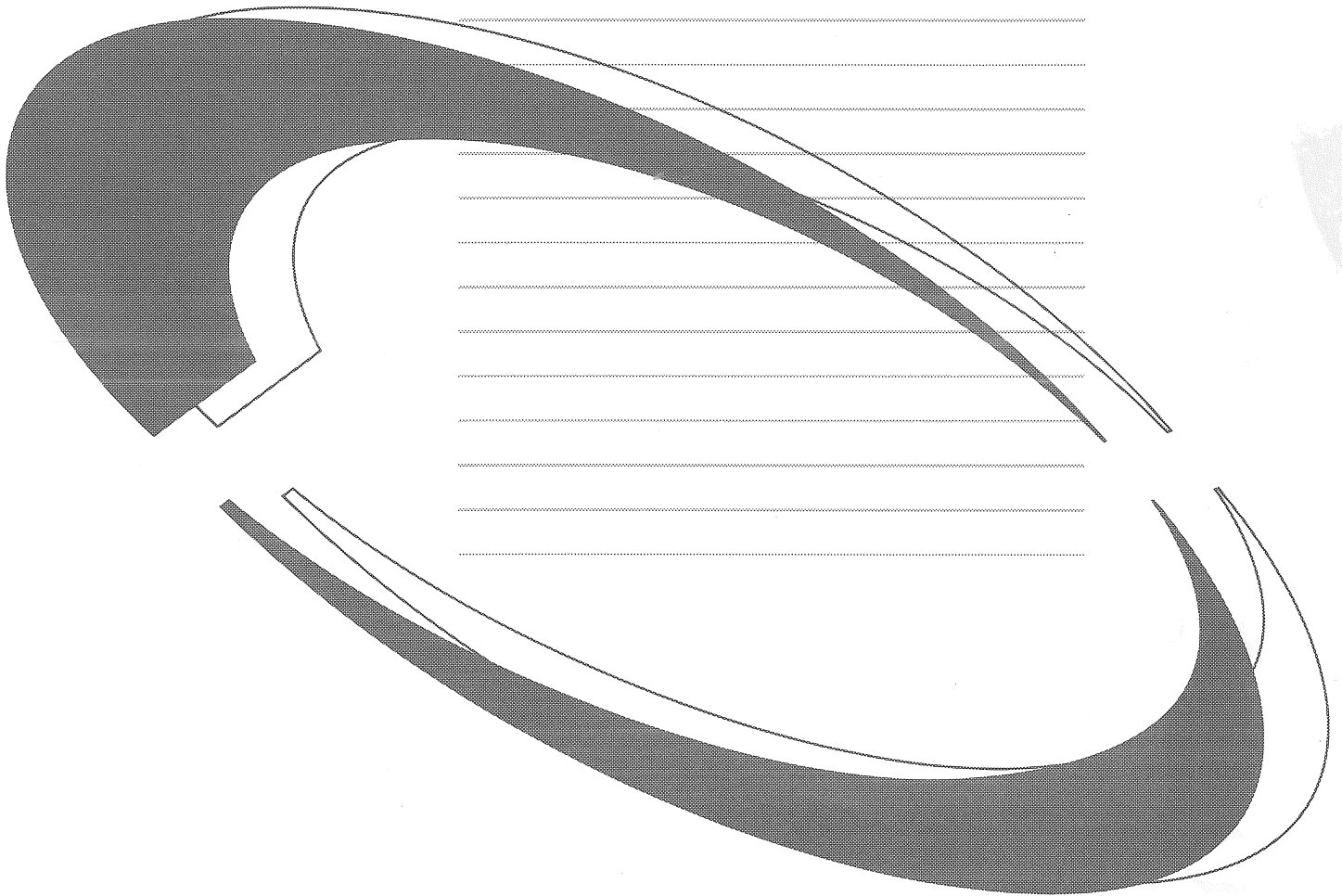

Premium Outdoor Power Equipment



Maruyama. Extraordinary.

Completely read and understand this manual prior to using this product.

Lisez et assimilez la totalité de ce manuel avant d'utiliser cet appareil.

Lea y entienda este manual a fondo, antes de usar este aparato.

TABLE OF CONTENTS

Foreword	1	Before operation.....	8
Safety symbols.....	1	Operating instructions.....	11
Warranty.....	2	Regular maintenance.....	13
Safety instructions.....	4	Storage.....	14
Specifications	7	Emission control information.....	15
Assembly instructions	7		

FOREWORD

This Owner's/Operator's Manual is designed to familiarize the operator with the various features and component parts of the equipment and to assist you with the assembly, operation and maintenance of your new Backpack Blower.

It is essential that any operator of this Backpack Blower product reads and understands the contents of this manual before using the Backpack Blower.

Important safety instructions will be identified by the following safety symbol:



Failure to comply with the instructions in this manual may result in serious injury or death.

For additional assistance, contact any local authorized Maruyama dealer or Maruyama U.S., Inc., 4770 Mercantile Drive, suite100, Fort Worth, TX 76137 U.S.A.

phone : 940-383-7400

web : www.maruyama-us.com

MANUAL SAFETY SYMBOLS

Throughout this manual and on the product itself, you will find safety alerts and helpful, information message preceded by symbols or key words. The following is an explanation of those symbols and key words and what they mean to you.



This symbol accompanied by the words **WARNING** and **DANGER** calls attention to an act or condition that can lead to serious personal injury to operator and bystanders.

Warning label

- Always remove dirt or mud to make the indications legible.
- The following alarm labels are attached.

Alarm label



Read Owner's/Operator's Manual thoroughly.
Make sure you read Owner's/Operator's Manual thoroughly prior to use.



Prohibition of fire
Don't put a naked flame close to a place where supplying fuel or doing maintenance.



Wear a protector.
Wear protectors such as hat, safety glasses, ear plugs during work.



Cautions for exhaust gas.
Take care not to breathe in exhaust gas from the engine.



Cautions for high temperatures
Muffler of engine, fin of cylinder, etc. are at high temperatures. Don't touch them.



Limited Warranty Statement

All Maruyama commercial/ industrial products are warranted to the original purchaser to be free from defects in material and workmanship **from the date of purchase** for the time periods listed as follows:

Lifetime for inner drive shaft on trimmers and brushcutters and all ignition modules.

5 years for Commercial and Residential use.

1 year for Rental use.

All Maruyama engines and Kawasaki TK45/TK65 are covered exclusively for five years of industrial, commercial, institutional, and income producing use. These engines are warranted for one year of rental use.

This warranty will be in full effect provided the engine is operated for the initial 80 hour optimization period using Maruyama Premium 2-Cycle oil. After the optimization period the engine should always be run with either Maruyama Premium 2-Cycle oil or equivalent ISO-L-EGD & JASO FC 2-Cycle oil.

Any part of a Maruyama product found to be defective within the applicable warranty period shall, at Maruyama's option, be repaired or replaced without charge. Warranty consideration is obtained by delivering any Maruyama product believed to be defective to an Authorized Maruyama Servicing Dealer within the applicable warranty period.

The purchaser shall not be charged for diagnostic labor that leads to the determination that a warranted part is defective, if the diagnostic work is performed at a Maruyama Dealer.

Any warranted part which is not scheduled for replacement as required maintenance, or which is scheduled only for regular inspection to the effect of "repair or replace as necessary" shall be warranted for the warranty period. Any warranted part, which is scheduled for replacement as, required maintenance shall be warranted for the period of time up to the first scheduled replacement point for that part.

Maruyama Mfg. Co., Inc. is liable for damages to other engine components caused by the failure of a warranted part still under warranty.

The purchaser is responsible for the performance of the required maintenance, as defined by Maruyama Mfg. Co., Inc. in the Owner's/Operator's Manual.

EMISSION-RELATED PARTS WARRANTY: In addition to the above warranty coverage, Maruyama Mfg. Co., Inc. will repair or replace, free of charge, for the original purchaser and each subsequent purchaser any emission-related part or parts found to be defective in material and workmanship for two (2) years from original retail delivery date **except catalytic converter. Catalytic converter is warranted one year from original retail delivery date. Emission-related parts are the carburetor assembly, the ignition coil assembly, the ignition rotor, the spark plug, the catalytic converter and the fuel tank.** Any replacement part that is equivalent in performance and durability may be used in non-warranty maintenance or repairs, and shall not reduce the warranty obligations of Maruyama Mfg. Co., Inc.

This warranty does not cover the following:

1. Maintenance items (excluding defects in materials and workmanship) including hoses, spark plugs, starter rope, air and fuel filters, clutch shoes, vibration isolators, throttle cables and all cutting attachments, etc.
2. Extra expenses including shipping and handling, travel, payment for lost time or pay and for any inconvenience and storage.
3. Alterations or modifications including aftermarket parts not authorized by Maruyama U.S., Inc.
4. Wear, accident, abuse, neglect, misuse, negligence, improper fuels, lubricants, fuel mixtures (when applicable), or failure to operate or maintain the product in accordance with instructions approved by Maruyama, repair or replacement as provided under this warranty is the exclusive remedy of the consumer.

Maruyama shall not be liable for any incidental or consequential damages for breach of any express or implied warranty on these products except to the extent prohibited by applicable law. Any implied warranty of merchantability or fitness for a particular purpose on these products is limited in duration to the warranty period as defined in the limited warranty statement. Maruyama reserves the rights to change or improve the design of the product without notice and does not assume obligation to update previously manufactured products.

This warranty provides you with specific legal rights, which may vary from state to state.

It is the Owner's and Dealer's responsibility to make sure the Warranty Registration Card is properly filled out and mailed to Maruyama U.S., Inc. Proof of purchase and registration will be required in order to obtain warranty service.

To locate an Authorized Maruyama Servicing Dealer nearest you, contact:

Maruyama U.S., Inc.
4770 Mercantile Drive, suite100,
Fort Worth, TX 76137 U.S.A.
940-383-7400
maruyama@maruyama-us.com
www.maruyama-us.com

⚠ WARNING: ⚠

The engine exhaust from this product contains chemicals known to the State of California to cause cancer, birth defects or other reproductive harm.

MARUYAMA LIMITED WARRANTY CALIFORNIA AND FEDERAL EMISSIONS CONTROL SYSTEMS SMALL OFF-ROAD ENGINES

The California Air Resources Board, the Environmental Protection Agency (EPA), and Maruyama, U.S. (hereinafter "Maruyama") are pleased to explain the Emissions Control Systems Warranty on your MY2012-2013 Maruyama small off-road engine. In California and other states, new small off-road engines must be designed, built and equipped to meet stringent anti-smog standards. Maruyama must warrant the emissions control system on your small off-road engine for the period of time listed below provided there has been no abuse, neglect or improper maintenance of your small off-road engine. Your emissions control system may include parts such as the carburetor or fuel-injection system, the ignition system, and catalytic converter. Also included may be hoses, belts, connectors and other emissions related assemblies. Where a warrantable condition exists, Maruyama will repair your small off-road engine at no cost to you including diagnosis (if the diagnostic work is performed at a Maruyama small off-road engine dealer), parts and labor.

OWNERS WARRANTY RESPONSIBILITIES. The following obligations must be fulfilled by the owner to maintain the validity of the Maruyama California / EPA Emissions Systems Warranty:

- (a) As the small off-road engine owner, you are responsible for the performance of the required maintenance listed in your Owner's/Operator's Manual. Maruyama recommends that you retain all receipts covering maintenance on your small off-road engine, but Maruyama cannot deny warranty solely for the lack of receipts or for your failure to ensure the performance of all scheduled maintenance.
- (b) You are responsible for presenting your small off-road engine to an authorized Maruyama small off-road engine Dealer as soon as a problem exists. The warranty repairs should be completed in a reasonable amount of time, not to exceed 30 days.
- (c) As the small off-road engine owner, you should also be aware that Maruyama may deny you warranty coverage if your small off-road engine or a part has failed due to abuse, neglect, improper maintenance or unapproved modifications.
- (d) If you have any questions regarding your warranty rights and responsibilities, you should contact Maruyama, U.S., INC., 4770 Mercantile Drive, suite 100, Fort Worth, TX 76137 U.S.A.

1. COVERAGE. Maruyama warrants to the initial owner and each subsequent purchaser that the small off-road engine is free from defects in materials and workmanship which cause a failure of a warranted part for a period of two years. Maruyama is liable for damages to other engine components caused by the failure of a warranted part still under warranty. The 1995 and later small off-road engines are warranted for two years in California. In all other states, 1997 and later model year small off-road engines are warranted for two years. If any emissions-related part on your engine is defective, the part will be repaired or replaced by Maruyama. This warranty time period shall begin on the date the small off-road engine is delivered to the initial purchaser, or on the date the small off-road engine is first placed in service.

Warranty defects shall be remedied during customary business hours at any authorized Maruyama small off-road engine dealer located within the United States of America. Any manufacturer-approved replacement part may be used in the performance of any warranty maintenance or repairs on emissions-related parts, and must be provided without charge to the owner if the part is still under warranty. Any part or parts replaced under this warranty shall become the property of Maruyama.

The emissions related warranted parts are specifically defined by the California Air Resources Board's Emissions Warranty Parts List. (EPA's regulations do not include a parts list, but EPA considers emissions-related parts to include all parts listed here.) These warranted parts are: carburetor and internal parts, spark advance/retard system, cold start enrichment system, magneto or electronic ignition system, catalytic converter, intake manifold, exhaust manifold, air cleaner element, carbon canister, fuel tank, fuel tank cap, and spark plugs if failure occurs prior to the first required scheduled replacement, hoses, clamps, fittings, gaskets, sealing devices, mounting hardware and tubing used directly in these parts. Since emissions related parts may vary slightly from model to model, certain models may not contain all of these parts and certain models may contain functionally equivalent parts.

2. LIMITATIONS. This Emissions Control Systems Warranty shall not cover any of the following:

- (a) Repair or replacement required as a result of (i) misuse or neglect, (ii) lack of required maintenance, (iii) repairs improperly performed or replacements improperly installed, (iv) use of replacement parts or accessories not conforming to Maruyama specifications which adversely affect performance and/or durability, (v) alterations or modifications not recommended or approved in writing by Maruyama.
- (b) Replacement of parts and other services and adjustments necessary for required maintenance at and after the first scheduled replacement point.

CONTINUED

3. LIMITED LIABILITY.

- (a) The liability of Maruyama under this Emissions Control Systems Warranty is limited solely to the remedying of defects in materials or workmanship by any authorized Maruyama small off-road engine dealer at its place of business during customary business hours. This warranty does not cover inconvenience or loss of use of the small off-road engine or transportation of the small off-road engine to or from the Maruyama Dealer. MARUYAMA SHALL NOT BE LIABLE FOR ANY OTHER EXPENSE, LOSS OR DAMAGE, WHETHER DIRECT, INCIDENTAL, CONSEQUENTIAL (EXCEPTION LISTED UNDER COVERAGE) OR EXEMPLARY ARISING IN CONNECTION WITH THE SALE OR USE OF OR INABILITY TO USE THE MARUYAMA SMALL OFF-ROAD ENGINE FOR ANY PURPOSE.
- (b) NO EXPRESS EMISSIONS CONTROL SYSTEMS WARRANTY IS GIVEN BY MARUYAMA WITH RESPECT TO THE MARUYAMA SMALL OFF-ROAD ENGINE EXCEPT AS SPECIFICALLY SET FORTH HEREIN. ANY EMISSIONS CONTROL SYSTEMS WARRANTY IMPLIED BY LAW, INCLUDING ANY WARRANTY OF MERCHANTABILITY OR FITNESS FOR A PARTICULAR PURPOSE, IS EXPRESSLY LIMITED TO THE EMISSIONS CONTROL SYSTEMS WARRANTY TERMS SET FORTH HEREIN. THE FOREGOING STATEMENTS OF WARRANTY ARE EXCLUSIVE AND IN LIEU OF ALL OTHER REMEDIES.
- (c) No dealer is authorized to modify this Maruyama Limited Emissions Control Systems Warranty.
- (d) Maruyama is not liable for parts which are not genuine Maruyama parts except when genuine Maruyama parts cause damage to non-Maruyama parts.

4. LEGAL RIGHTS. THIS WARRANTY GIVES YOU SPECIFIC LEGAL RIGHTS, AND YOU MAY ALSO HAVE OTHER RIGHTS.

5. THIS WARRANTY IS IN ADDITION TO THE MARUYAMA LIMITED SMALL OFF-ROAD ENGINE WARRANTY.

1/1/2013



WARNING



1. Read and understand this Owner's/Operator's Manual before using the power blower. Be thoroughly familiar with the proper use of the power blower.
2. Never allow children to operate the power blower. It is not a toy. Never allow adults to operate the unit without first reading the Owner's / Operator's Manual.
3. Become familiar with the controls and know how to stop the engine quickly.
4. Always use eye protection and hearing protection.
5. Keep the area of operation clear of all persons, particularly small children and pets.
6. Do not point the blower nozzle in the direction of people or pets.
7. Never operate a power blower when you are fatigued.
8. Never operate a power blower without proper guards or other protective safety devices in place.
9. Dress properly; do not wear loose clothing or jewelry that can be caught in moving parts. Always wear substantial footwear, long pant, and long sleeved shirt.
10. Gasoline is highly flammable; handle it carefully.
 - A. Do not smoke while handling gasoline.
 - B. Use an approved fuel container for storing the gasoline/oil mixture.
 - C. Do not fill the fuel tank when the engine is hot or running
 - D. Fill the fuel tank outdoors and only up to one-half inch from the top of the tank. Do not fill the filler neck.
 - E. Wipe away any spilled gasoline before starting the engine.
11. Always be sure of your footing; keep a firm hold of the blower pipes, and walk, never run while operating a power blower.
12. Use the correct accessories. Do not use the power blower for any job except that for which it is intended .
13. Keep all fasteners tight and be sure the power blower is in safe working condition. Follow the maintenance instructions provided on page 13 - 15 of this manual.
14. Do not put hands or feet near or under the rotating parts. Keep clear at all times.
15. If the power blower should start to vibrate abnormally, stop the engine immediately and check for the cause. Vibration is generally a warning of trouble.
16. Avoid using the power blower near rocks, gravel, stones and similar matter in order to avoid dangerous flying debris.
17. Use the power blower only in daylight or good artificial light.
18. Do not allow bystanders in work area.
19. Do not operate without guard(s) in place.
20. Do not operate in unventilated area.
21. To reduce the risk of injury associated with the inhalation of dust, use a face filter mask in dusty conditions.
22. To reduce the risk of injury associated with contacting rotating part, stop the engine before installing or removing attachments.
23. To reduce the risk of fire and burn injury:
 - Move at least 10ft (3m) away from the fueling point before starting engine.
 - Always store gasoline in approved container.

Operating techniques

- A. Operate power equipment only at reasonable hours - not early in the morning or late at night when people might be disturbed. Comply with times listed in local ordinances. Usual recommendations are 9:00 am. to 5:00 p.m., Monday through Saturday.
- B. To reduce noise levels, limit the number of pieces of equipment used at any one time.
- C. To reduce noise levels, operate power blowers at the lowest possible throttle speed to do the job.
- D. Check your equipment before operation, especially the muffler, air intakes, and air filters.
- E. Use rakes and brooms to loosen debris before blowing.
- F. In dusty conditions, slightly dampen surfaces when water is available.
- G. Conserve water by using power blowers instead of hoses for many lawn and garden applications, including areas such as gutters, screens, patios, grills, porches, and gardens.
- H. Watch out for children, pets, open windows, or freshly washed cars, and blow debris safely away.
- I. Use the full blower nozzle extension so the air stream can work close to the ground.
- J. After using blowers and other equipment, CLEAN UP! Dispose of debris in trash receptacles.

SPECIFICATIONS

Models	BL5100	BL8200
Dimensions L x W x H	14.4 x 20 x 18.7 in. (365 x 510 x 475 mm)	
Dry Weight	19.1 lbs. (8.7 kg)	20.7 lbs. (9.4 kg)
Engine Type	TK45 for EPA	Kawasaki/2-Stroke Air cooled TK65 for EPA
Displacement	45.4 cc	64.7 cc
Ignition System	Electric	
Carburetor	All position diaphragm	
Fuel Tank Capacity	2.1 gal (2.0 lit)	
Fuel Mixture:	50:1 Using Maruyama 50:1 2-Cycle Engine Oil or any quality 2-cycle engine oil designed for use in air-cooled, high performance 2-cycle engines.	

The MARUYAMA BACKPACK POWER BLOWER comes with an Owner's / Operator's Manual and a Warranty Registration Card. Assembly and attachment of the throttle lever bracket and blower pipes are required.

ASSEMBLY INSTRUCTIONS

STEP #1) Locate and identify all the components (see sketch).

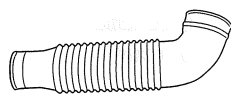

FLEXIBLE PIPE

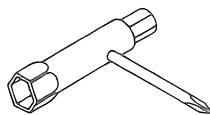

BOX SPANNER

BANDS(S)



4.0 in.



OPERATOR'S
MANUAL

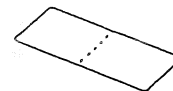

WARRANTY
REGISTRATION CARD

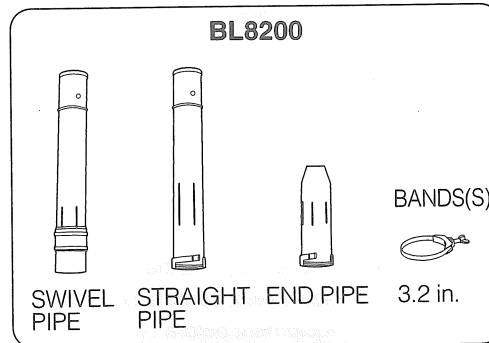
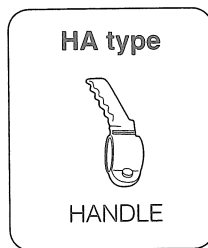
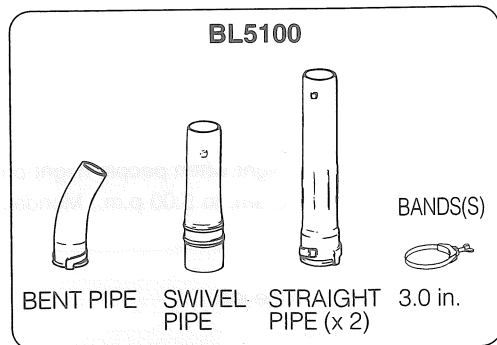

- STEP #2) Using the BANDS, connect the FLEXIBLE PIPE to the blower, and the SWIVEL PIPE to the flexible pipe (see sketch page 8).
- STEP #3) Assemble the STRAIGHT PIPE, BENT PIPE, and FAN-BLOW HEAD, then connect them to the swivel pipe (see sketch page 8).
- STEP #4) Slide handle over swivel pipe and tighten retainer knob. (see sketch page 8).

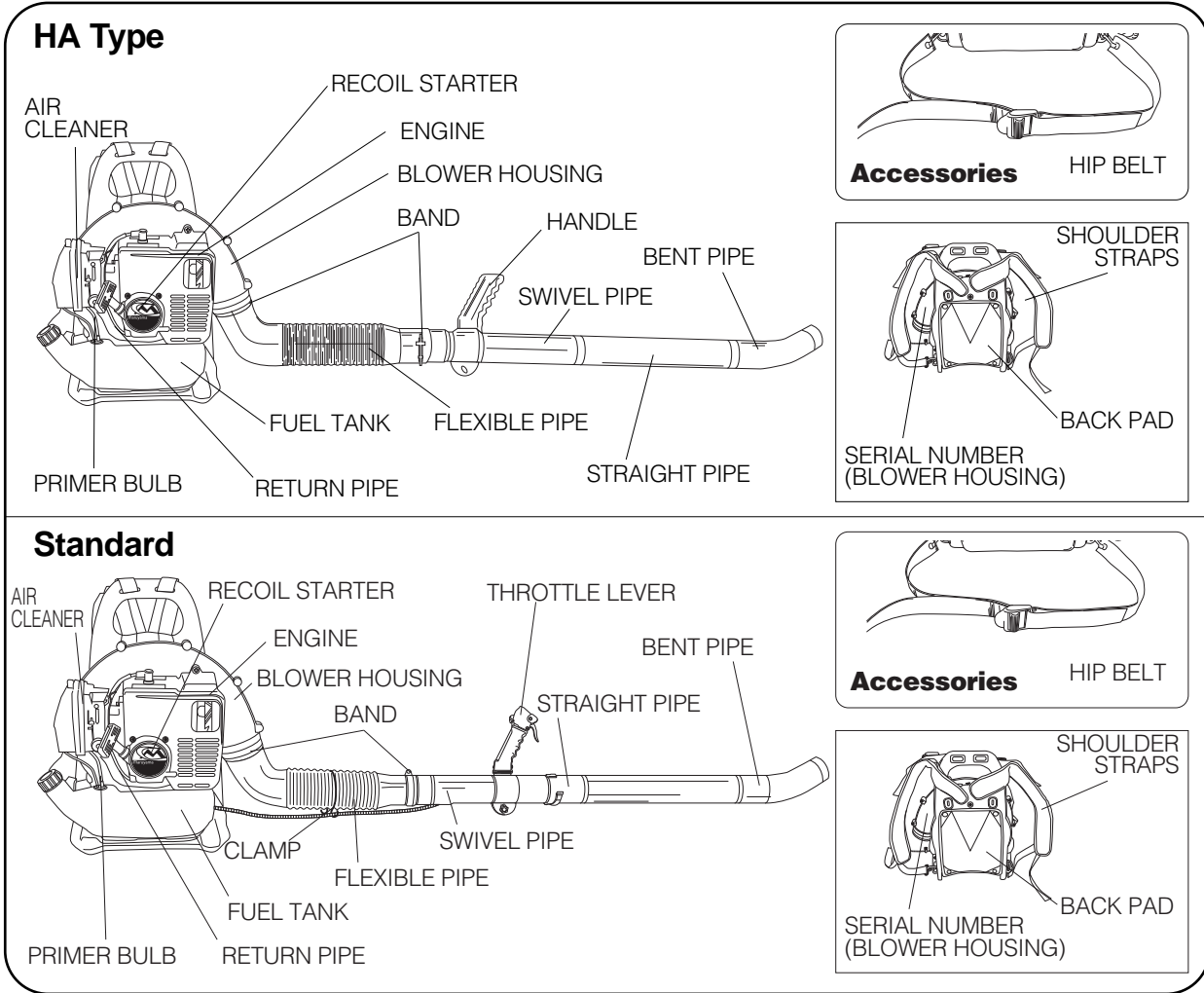

BEFORE OPERATION

Be sure the power blower is correctly assembled and all fasteners and fittings are properly secured.

THROTTLE LEVER

HA Type

Before operating the power blower, release the knob, rotate the throttle arm to the position in the illustration, and tighten knob to secure in place.

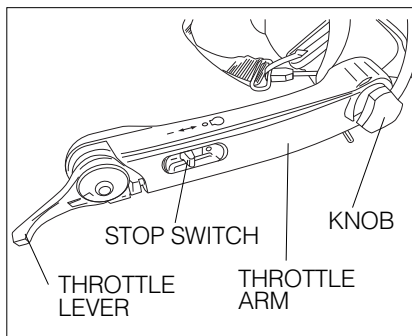

When the power blower is strapped to the back of the operator, the throttle lever of the "Standard" is located on the left side.

Standard

Before operating the power blower, release the knob, knove the throttle grip to the position in the illustration, and tighten knob to secure in place.

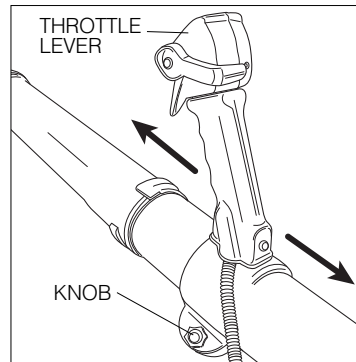

When the power blower is strapped to the back of the operator, the throttle lever of is located on the tube.

1.Catalytic Converter

This product is equipped with a catalytic converter in the exhaust system to significantly reduce exhaust emissions. The catalytic converter converts carbon monoxide and hydrocarbons into harmless carbon dioxide and water.

The catalytic converter requires special care.

- Use only unleaded gasoline. Never use leaded gasoline. Leaded gasoline significantly reduces the capability of the catalytic converter.
- Do not use 2-cycle oil that contains Phosphorus (P), Lead (Pb), or Sulfur (S). These elements will reduce the life and performance of the catalytic converter.

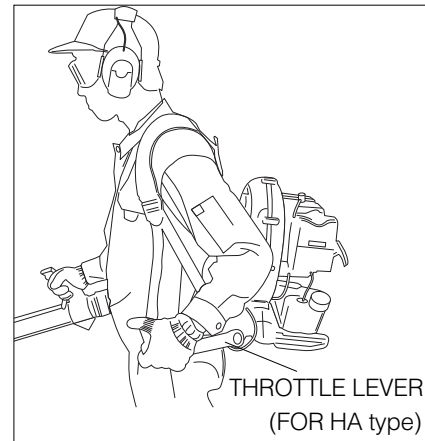

CAUTION!

2.Shutting Engine Off

Before shutting the engine off, allow it to idle for a short while.

- Never stop the engine by closing the choke.
- Never stop the engine during operation while running above idle speed.

3.Transporting and Storage

- Shut off the engine and allow it to cool before transporting or storing the unit.
- Do not put the unit on dry grass or near any flammable object unless the engine is cold or cooled down.

HA Type

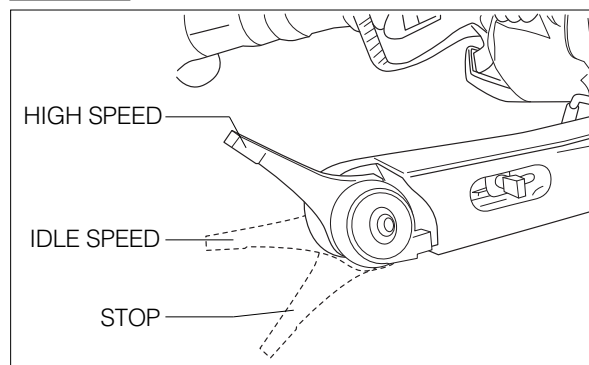

The lowest position of lever is "IDLE" setting, and the highest position is the "FULL THROTTLE" setting.

Standard

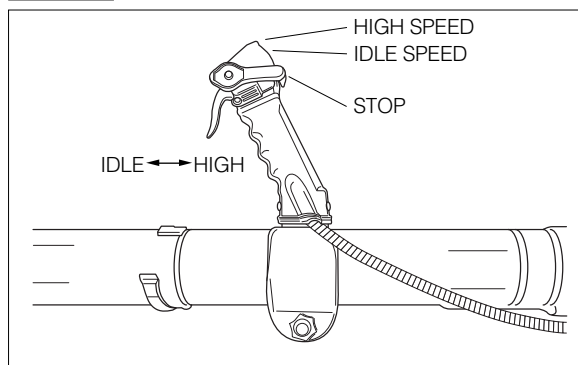

The lowest position of lever is "STOP" setting, and the highest position is the "FULL THROTTLE" setting.

FUEL: MIXING GASOLINE AND OIL

CAUTION! The engine used on this Backpack blower is of a 2-cycle design. The internal moving parts of the engine, i.e., crankshaft bearings, piston pin bearings and piston to cylinder wall contact surfaces, require oil mixed with the gasoline for lubrication. Failure to add oil to the gasoline or failure to mix oil with the gasoline at the appropriate ratio will cause major engine damage which will void your warranty. For your fuel premix, only use Maruyama 50:1 2-Cycle Oil or a quality oil designed for 2-cycle air-cooled engine.

FUEL MIXTURE: When using genuine Maruyama 50:1 2-Cycle Oil, or a quality oil designed for 2-cycle air-cooled engines, oil ratio is 50 parts gasoline to 1 part oil or 50:1.

FUEL; MIXING GASOLINE AND OIL

CAUTION! If Maruyama brand oil is not used, never use a mixing ratio less than 50:1 regardless of the oil package mixing instructions. Ratios less the 50:1, (for example, 60:1, 80:1, 100:1), reduce the amount of lubrication to the internal moving parts of the engine and can cause damage.

Gasoline	50:1 2-Cycle Oil
1 gallon	2.6 oz.
2 1/2 gallons	6.4 oz.
5 gallons	12.8 oz.

MIXING INSTRUCTIONS: Always mix fuel and oil in a clean container approved for gasoline. Mark the container to identify it as fuel mix for the Backpack Blower. Use regular unleaded gasoline and fill the container with half the required amount of gasoline. Pour the correct amount of oil into the container then add the remaining amount of gasoline. Close the container tightly and shake it momentarily to evenly mix the oil and the gasoline before filling the fuel tank on the Backpack Blower.

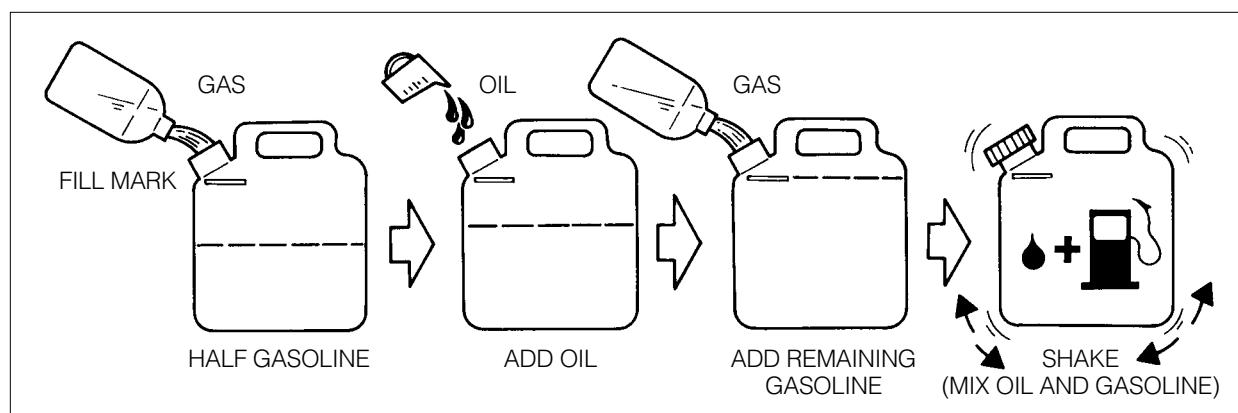

When refilling the Backpack Blower fuel tank, clean around the fuel tank cap to prevent dirt and debris for entering the tank during cap removal. Always shake the premix fuel container momentarily before filling the fuel tank.

Always use a spout or funnel when fueling to reduce fuel spillage. Only fill the tank to within 1/2 inch from the top of the tank. Avoid filling to the top of the tank filler neck.

NOTE:

1. Never mix gasoline and oil directly in the Backpack Blower fuel tank.

CAUTION!

1. Do not use National Marine Manufacturer's Association (NMMA) or BIA certified oils. This type or 2-cycle engine oil does not have the proper additives for air-cooled, 2-cycle engines and can cause engine damage.
2. Do not use automotive motor oil. This type of oil does not have the proper additives for air-cooled, 2-cycled engines and can cause engine damage.

OPERATING INSTRUCTIONS

STARTING PROCEDURE

STEP #1)

Pump the "PRIMER BULB" under of the carburetor until fuel can be seen flowing through the "FUEL-RETURN LINE".

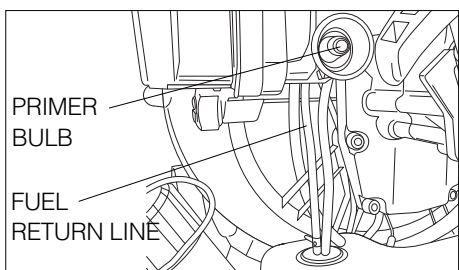

STEP #2)

Move the "CHOKE LEVER" fully up ward to the closed position. If the engine is already warm, only a partial or open (no choke) choke setting may be required.

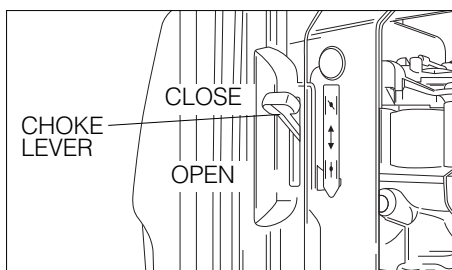

HA Type

STEP #3)

Turn the stop switch ON. (Confirm that the stop switch is at the starting position.)
Set the throttle lever at 1/2 speed.

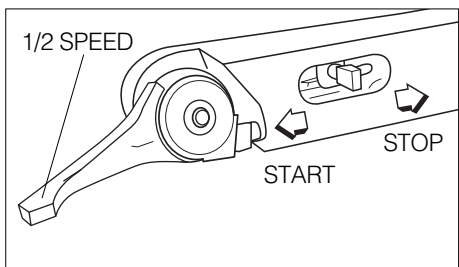

Standard

STEP #3)

Set the throttle lever at 1/2 speed.

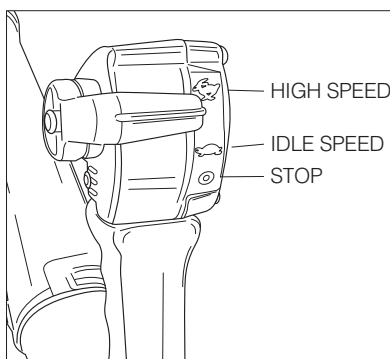

CAUTION!

Press down the "AIR FILTER COVER" and Pull the "STARTER GRIP" briskly to start the engine.

NOTE: Only short pulls are necessary. Never pull the starter cord to its fullest extension. Never let go of the

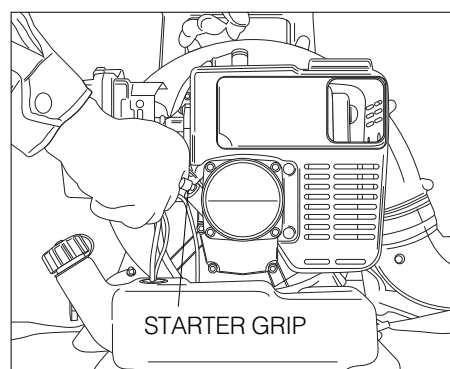

- STEP #4) Warming up the engine.**
When the engine has started, slowly move the "CHOKE LEVER" fully upward to the open position. Allow the engine to "WARM-UP" at less than 1/2 speed.

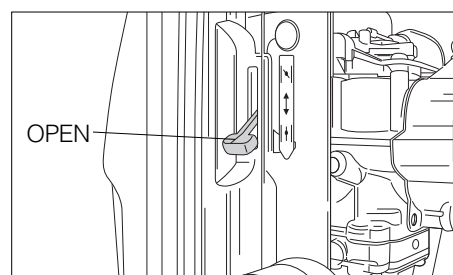

If a MARUYAMA engine fails to start after following the above procedures, contact an authorized MARUYAMA dealer.

BLOWER OPERATION

When the engine has warmed-up, the power blower can be positioned on the back of the operator.

When the power blower is positioned and ready for operation, adjust the throttle to a speed required to accomplish the task.

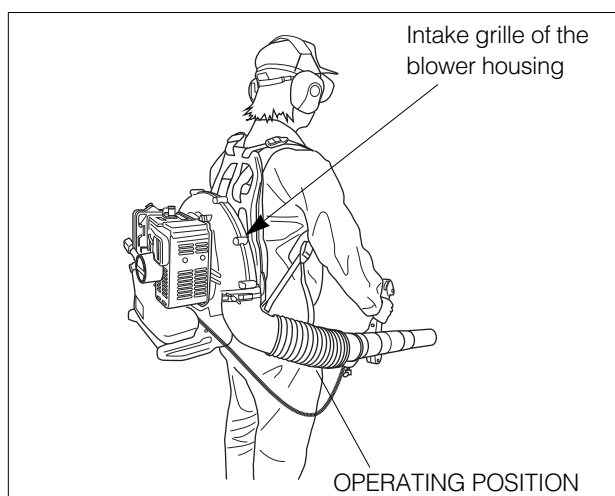

! WARNING

- Never operate a power blower when you are fatigued.
- Never operate a power blower without proper guards or other protective safety devices in place.

! WARNING

To prevent overheating and engine seizure, cooling air comes from the intake grille of the fan housing and is pushed by the blower fan through an opening in the fan housing over the cylinder fin area, taking away combustion heat. The grille and cylinder fins must be kept clean of grass, dust and any debris. Engine failure due to lack of this "Normal Maintenance" is not covered by warranty.

STOPPING THE ENGINE

Always run the engine at idle speed for a few minutes to allow cooling before stopping. To stop the engine, move the throttle control lever all the way to the engine stop position, or move the stop switch to the "STOP" position.

REGULAR MAINTENANCE

Before each use, the power blower should be inspected for proper assembly and fitness of all components. All fasteners should be checked for correct tightness. Always inspect for fuel leaks.



WARNING Do not attempt to start or operate a power blower that indicates a fuel leak.

AIR FILTER

The air filter should be inspected each time the power blower is used (or more often with extreme conditions).

To inspect, remove the air filter cover and remove the filter from the case.

Clean air filter(s) by gently tapping element or cleaning with a suitable solvent the filter should be completely dry before using again.

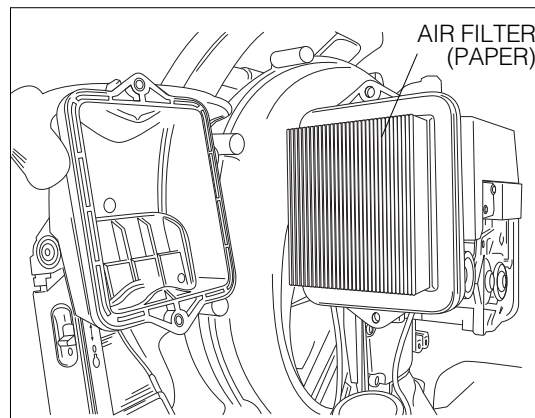

SPARK PLUG

The spark plug should be removed from the engine and checked after each fifty (50) hours of use. The tips can be cleaned with a stiff brush. Adjust the gap to 0.031 - 0.035 inches (see sketch). Replace the spark plug if it is oil-fouled or damaged.

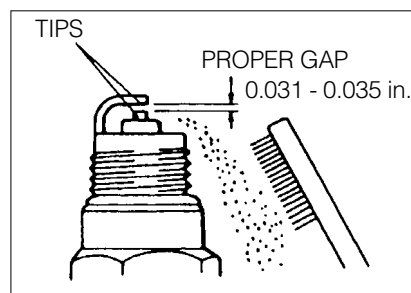

CAUTION!

The correct torque for the spark plug is 10 - 12 ft. lbs. Do not over-tighten.

FUEL FILTER

The fuel filter should be cleaned and inspected for damage after each twenty (20) hours of use. The fuel filter is attached to the fuel pick-up tube inside the fuel tank. Loosen the clamp and take out the fuel filter.

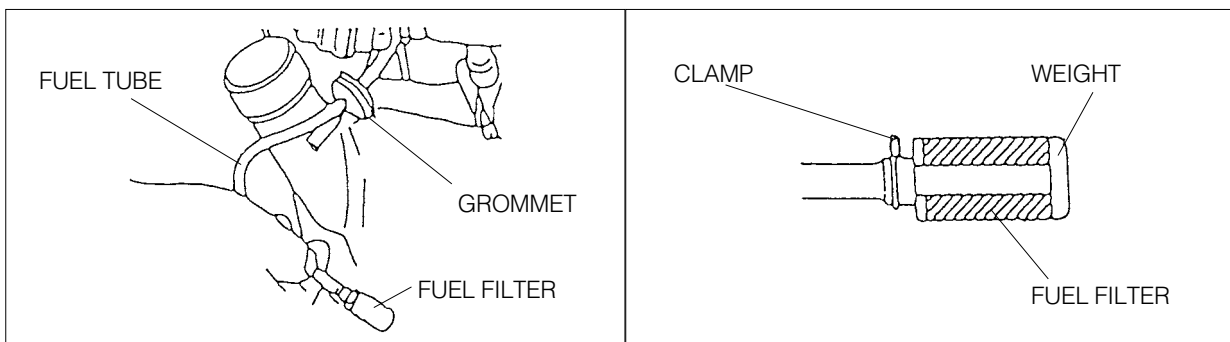

To clean the fuel filter, remove it from the fuel tube and wash it with safety solvent. Inspect and clean the fuel tank before re-installing the fuel filter.

Always replace a defective fuel filter.

COOLING FINS

Free passage of air flow through the cylinder cooling fins is required to prevent poor engine performance and shortened engine life. Regularly check and clean all debris from the cooling fins by removing the engine cover (see sketch).

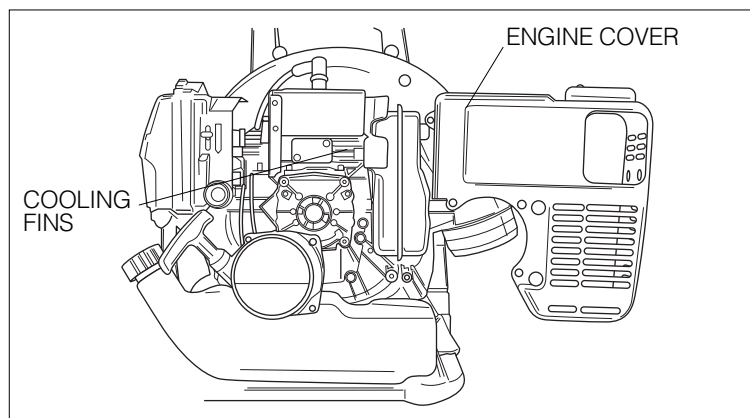

MUFFLER AND EXHAUST PORTS

The muffler should be removed and serviced after each fifty (50) hours of use. At the same time, the exhaust ports should be cleaned and inspected. An AUTHORIZED MARUYAMA DEALER should be contacted for this service.

GENERAL CLEANING AND TIGHTENING

The MARUYAMA power blower will provide maximum performance for many hours, if it is maintained properly. Good maintenance includes regular checking of all fasteners for correct tightness, and cleaning the entire machine. Contact an authorized MARUYAMA dealer for additional maintenance suggestions.

STORAGE

For long-term storage of the power blower, first perform all regular maintenance procedures and needed repairs. Empty the fuel tank. Disconnect the fuel supply line from the carburetor and depress the primer bulb until fuel stops discharging from the fuel-return line.

Start the engine and allow it to run until it stops. Pull the starter cord a few times to remove any excess fuel from the engine. Remove the spark plug and insert a small amount of oil into the cylinder. Slowly pull the starter cord and bring the piston to a position closest to the spark plug hole. Re-install the spark plug. Apply a thin coating of oil to all the metal surfaces and store the power blower in a dry place.

EMISSION CONTROL INFORMATION

FUEL INFORMATION

THIS ENGINE IS CERTIFIED TO OPERATE ON UNLEADED REGULAR GRADE GASOLINE ONLY. A minimum of 87 octane of the antiknock index is recommended. The antiknock index is posted on service station pumps in the U.S.A..

EMISSION CONTROL INFORMATION

To protect the environment in which we all live, Kawasaki has incorporated an exhaust emission control system.

EXHAUST AND EVAPORATIVE EMISSION CONTROL SYSTEM

The system reduces the amount of pollutants discharged into the atmosphere by the exhaust of this engine. The fuel tank, ignition and exhaust systems of this engine have been carefully designed and constructed to ensure an efficient engine with low exhaust pollutant and low evaporate emission levels. If you purchased your (Blower, Trimmer, Hedge Trimmer) in the state of California, the engine included catalytic converter system, and the fuel tank includes low evaporative emission system.

MAINTENANCE AND WARRANTY

Proper maintenance is necessary to ensure that your engine will continue to have low emission levels. This Owner's/Operator's Manual contains those maintenance recommendations for your engine. Those items identified by the Periodic Maintenance Chart are necessary to ensure compliance with the applicable standards.

As the owner of the (Blower, Trimmer, Hedge Trimmer), you have the responsibility to make sure that the recommended maintenance is carried out according to the instructions in this Owner's/Operator's Manual at your own expense.

The Maruyama Limited Emission Control System Warranty requires that you return your (Blower, Trimmer, Hedge Trimmer) to an authorized Maruyama (Blower, Trimmer, Hedge Trimmer) dealer for remedy under warranty. Please read the warranty carefully, and keep it valid by complying with the owner's obligations it contains.

TAMPERING WITH EMISSION CONTROL SYSTEM PROHIBITED

Federal law and California State law prohibit the following acts or the causing there of: (1) the removal or rendering inoperative by any person other than for purposes of maintenance, repair, or replacement, of any device or element of design incorporated into any new engine for the purposes of emission control prior to its sale or delivery to the ultimate purchaser or while it is in use, or (2) the use of the engine after such device or element of design has been removed or rendered inoperative by any person.

Among those acts presumed to constitute tampering are acts listed below:

Do not tamper with the original emission related parts.

- Carburetor and internal parts
- Spark plug
- Magneto or electronic ignition system
- Fuel filter
- Muffler or any internal portion of the muffler
- Air cleaner element
- Fuel Tank

FUEL RECOMMENDATIONS

FUEL

The Kawasaki TK series 2-stroke engines require a gasoline-oil mixture.
Use only clean, fresh, unleaded regular grade gasoline.

Octane Rating

The octane rating of a gasoline is a measure of its resistance to "knocking".
Use of a minimum of 87 octane of the antiknock index is recommended. The antiknock index is posted on service station pumps in the U.S.A.

NOTE:

- If "knocking or pinging" occurs, use a different brand of gasoline or higher octane rating.

⚠ WARNING: ⚠

Gasoline is extremely flammable and can be explosive under certain conditions. Turn the engine switch OFF. Do not smoke. Make sure the area is well ventilated and free from any source of flame or sparks : this includes any appliance with a pilot light.

2-STROKE ENGINE OIL MIXING

Oil must be mixed with the gasoline to lubricate the piston, cylinder, crankshaft, bearings, and connecting rod bearings.

Recommended Engine Oil: 2-stroke air cooled brand oil

Gasoline and engine oil mixing ratio: 50 : 1 (gasoline 50, 2-stroke Engine Oil 1)

NOTE:

- Do not mix gasoline and oil directly in the fuel tank.
- The lubricative quality of this mixture deteriorates rapidly.
- Do not use gasoline that has been stored longer than two months.
- To ensure proper starting at low ambient temperatures, fresh winter grade fuel must be used.

CAUTION: The engine is shipped without fuel.

ADJUSTMENT

IDLING SPEED ADJUSTMENT

1. Idle speed is the only available adjustment.
2. Do not tamper with the carburetor setting to increase the maximum engine speed.
3. If adjustment is needed, have it performed by your authorized MARUYAMA service dealer.
Carburetor adjustments are made at the factory and are not adjustable without disassembling the carburetor.

MAINTENANCE

PERIODIC MAINTENANCE CHART

⚠ WARNING: ⚠

Always remove the spark plug cap from spark plug when servicing the engine to prevent accidental starting.

MAINTENANCE	Interval				
	Daily	First 20 hours	Every 20 hours	Every 50 hours	Every 100 hours
Check and replenish fuel	●				
Check for fuel leakage	●				
Check bolts, nuts and screws for looseness and loss	●				
Clean fuel filter			●		
★ Clean air filter element			●		
Tighten bolts and nuts		●		●	
Clean spark plug and adjust electrode gap				●	
★ Remove dust and dirt from cylinder fins				●	
M Remove carbon deposits on piston head and inside cylinder				●	
M Remove carbon deposits in the exhaust pipe of muffler				●	
M Clean net of spark arrester (if equipped)				●	
M Check the sliding portion of crankshaft, connecting rod etc.					●
Fuel tube	It is recommended to replace every 3 years.				

Note: The service intervals indicated are to be used as a guide. Service to be performed more frequently as necessary by operating condition.

M: Service to be performed by an authorized Maruyama engine dealer.

★: Service more frequently under dusty conditions.



Maruyama U.S., Inc.

4770 Mercantile Drive, suite100,

Fort Worth, TX 76137 U.S.A.

Phone 940-383-7400

Fax 940-383-7466

www.maruyama-us.com

P/N 131322-03 13.05 TAP/F